



Basorplast: **Uses & Installation** **Practices**

Usos y creación de accesorios



Index Índice

USES USOS

3 / Introduction / Presentación

4-22 / Product uses / Usos del producto

1. Water Treatment
Tratamientos de Agua
2. Mining
Minería
3. Chemical Industry
Industria Química
4. Railways
Ferrocarriles
5. Solar Installations
Instalaciones Solares
6. Sea and Ports
Mar y Puertos
7. Machine Building
Construcción de maquinaria
8. Shore and Cost
Litoral y Costas
9. Metal Chemical Industry
Industria Química Metálica

23- 25 / Products that PVC can replace

Productos que el PVC puede sustituir

- Advantages
Ventajas
- Disadvantages
Desventajas

INSTALLATION PRACTICES CREACIÓN DE ACCESORIOS

26/ Cutting / Corte

27/ Tools and mounting accessories Herramientas y accesorios de montaje

28/ Straight Junctions / Uniones rectas

29/ Horizontal bends / Curvas planas

- a. Small radius / Radio corto
- b. Right radius / Radio recto
- c. Large radius / Radio largo
- d. Other radius / Otros radios

33/ Inside bends / Curvas cóncavas

- a. Small radius / Radio corto
- b. Right radius / Radio recto
- c. Large radius / Radio largo

36/ Outside bends / Curvas convexas

- a. Small radius / Radio corto
- b. Right radius / Radio recto
- c. Large radius / Radio largo

39/ Tee bends / Tés

40/ Cross bends / Cruces

41/ Elevation changes / Cambios de nivel

42/ Application on strut / Aplicación en perfil

- a. Solid bottom / Ciegas
- b. Slotted / Perforadas

44/ Product Catalogue / Catálogo de Productos

50/ Application on brackets

/ Aplicación en soporte

- a. Floor / Suelo
- b. Wall / Pared
- c. Ceiling / Techo

Introduction Introducción

BPE 60x100 to 60x300



BPE 100x200 to 100x600



Models (HxB) / Modelos (AxB):

60x100; 60x150; 60x200; 60x300; 100x200; 100x300; 100x400; 100x600.

Types: Slotted or solid bottom / Tipos: Perforadas o ciegas

Finishes / Acabados: PVCM1 UV RAL 7035

Characteristics of the tray / Características de la bandeja:

- Non metallic system / Sistema no metálico
- Resistant to UV radiation / Resistente a los rayos UV
- Excellent behaviour in outdoor / Excelente comportamiento al exterior
- Impact strength: 20J except 60x100 with 10J
Resistencia al impacto: 20J salvo 60x100 con 10J
- Minimum temperature / Temperatura mínima: -4°F (-20°C)
- Maximum temperature / Temperatura máxima: 140°F (60°C)
- Non-Flame propagating / No propagador de la llama
- No electrical continuity / Sin continuidad eléctrica
- Insulating / Aislante
- Dielectric Strength / Rigidez dieléctrica: 18+/-2 KV/mm
- High resistance to corrosion substances / Alta resistencia a las sustancias corrosivas
- M1 reaction to fire/ Reacción M1 al fuego: UNE 23727
- Glow wire test / Test de llama incandescente: 1760°F (960°C) EN 60695-2-11
- Flammability / Inflamabilidad: UL 94-VO, ANSI/UL 94-1995
- LOI > 50% EN ISO 4589
- Comply / Cumple: RoHS 2002/95/CE
- Raw material without silicone / Materia prima sin silicona

INSTRUCTIONS FOR USE

- **Assembly:** H60 (2 union joints + 4 bolts)
H100 (2 union joints + 8 bolts).
- **Installation:** Not allowed under other canalisation such as water, vapour or gas.
- **Ventilation:** Minimum distance between each tray of 250mm.
- **Enviroments:** Wet, salty and chemical.
- **Expansions:** Depending of the expected growth in the temperatura (AT) leave a gap (h) between cable trays according to the following table.

INSTRUCCIONES DE USO

- **Ensamblado:** H60 (2 uniones + 4 tornillos)
H100 (2 uniones + 8 tornillos)
- **Instalación:** No permitido bajo otras canalizaciones como agua, vapor o gas.
- **Ventilación:** Distancia mínima entre bandejas de 250mm.
- **Ambientes:** Húmedos, salinos y químicos.
- **Expansiones:** Dependiendo de las variaciones de temperatura (AT) dejar un espacio (h) entre las bandejas acorde a la siguiente tabla.

ΔT (°F)	ΔT (°C)	h (mm)
68	20	5
86	30	7
104	40	9
122	50	11

Temp. Max 40° (104 F°)	Safe Working Load Carga de trabajo admisible - kg/m (lb/ft)		
	2,4m (8ft)	1,8m (8ft)	1,5m (5ft)
BPE-60X100	3,1 (2,1)	5,5 (3,7)	8 (5,4)
BPE-60X150	4,2 (2,8)	7,6 (5,1)	10,9 (7,3)
BPE-60X200	19,3 (13)	34,3 (23,1)	49,5 (33,2)
BPE-60X300	21,2 (14,2)	37,8 (25,4)	54,4 (36,5)
BPE-100X200	33,1 (22,3)	59 (39,6)	84,9 (57,1)
BPE-100X300	54,2 (35,2)	93,2 (62,6)	134,3 (90,2)
BPE-100X400	81,3 (54,6)	144,6 (97,2)	208,3 (140)
BPE-100X600	121,7 (81,8)	216,5 (145,4)	311,7 (209,5)

Temp. Max 60° (140 F°)	Safe Working Load Carga de trabajo admisible - kg/m (lb/ft)		
	2,4m (8ft)	1,8m (8ft)	1,5m (5ft)
BPE-60X100	2 (1,3)	3,6 (2,4)	5,2 (3,5)
BPE-60X150	2,7 (1,8)	4,9 (3,3)	7,1 (4,7)
BPE-60X200	12,6 (8,4)	22,4 (15)	32,2 (21,6)
BPE-60X300	13,8 (9,3)	24,6 (16,5)	35,4 (23,8)
BPE-100X200	21,6 (14,5)	38,4 (25,8)	55,3 (37,1)
BPE-100X300	34,1 (22,9)	60,7 (40,8)	87,4 (58,7)
BPE-100X400	53 (35,6)	94,2 (63,3)	135,7 (91,1)
BPE-100X600	79,3 (53,3)	141 (94,7)	203 (136,4)

Water treatment Tratamiento de aguas

Water treatment is any process that makes water more acceptable for a specific end-use such as drinking, industrial water supply, irrigation or others. **These kind of places with a lot of humidity need materials such as PVC to avoid the corrosion and guarantee a long life of the installation.**

El tratamiento de aguas es cualquier proceso que mejora la calidad del agua para un uso final específico, ya sea para beberla, suministro industrial, riego u otros. **Este tipo de lugares con una alta humedad necesita de materiales como el PVC para evitar la corrosión y garantizar una vida larga de la instalación.**





Desalination plants:

Saline water can be treated to yield fresh water. Two main processes are used, reverse osmosis or distillation. **The PVC trays are perfect to be installed because this material is not affected by salty environment.**

Desalinizadoras:

El agua salada puede ser tratada para convertirse en agua dulce. Dos procesos fundamentales se utilizan, la osmosis o la destilación. **Las bandejas de PVC son perfectas para ser instaladas en estas plantas dado que no se ven afectadas por el ambiente de salinidad.**



Pumping stations:

Pumping stations are facilities including pumps and equipment for pumping fluids from one place to another such as canals or stored liquid areas as well as the drainage of low-lying land. **These places need non metallic trays due the big humidity of the environment.**

Plantas de bombeo:

Las estaciones de bombeo son instalaciones que incluyen bombas y equipos para bombear fluidos de un lugar a otro como canales o áreas con líquidos estancados, así como para el drenaje de tierras bajas. **Estos lugares necesitan bandejas no metálicas debido a la alta humedad del ambiente.**

Wastewater treatment

Is a process used to convert water no longer needed into an effluent that can be either returned to the water cycle with minimal environment issues removing the impurities. This process generates a lot of gases. **These gases are corrosive, for this reason the PVC trays is the most efficient solution to this environments.**

Tratamiento de fecales

Es un proceso usado para convertir el agua que ya no se necesita en un afluente que puede ser devuelto al ciclo del agua sin apenas problemas ambientales gracias a la eliminación de las impurezas. Este proceso genera una gran cantidad de gases. **Estos gases son corrosivos, por lo que las bandejas de PVC son la solución más eficiente a estos ambientes.**



Pools

Is a structure designed to hold liquids. Pools can be built into the ground or above. **In the maintenance of these facilities, the use of chemical products such as chlorine is very usual, PVC trays are the perfect products for these environments.**

Piscinas

Es una estructura diseñada para mantener líquidos. Las piscinas se pueden construir en el suelo o elevadas. **En el mantenimiento de estas instalaciones, el uso de productos químicos como el cloro es muy habitual, las bandejas de PVC son los productos perfectos para estos entornos.**

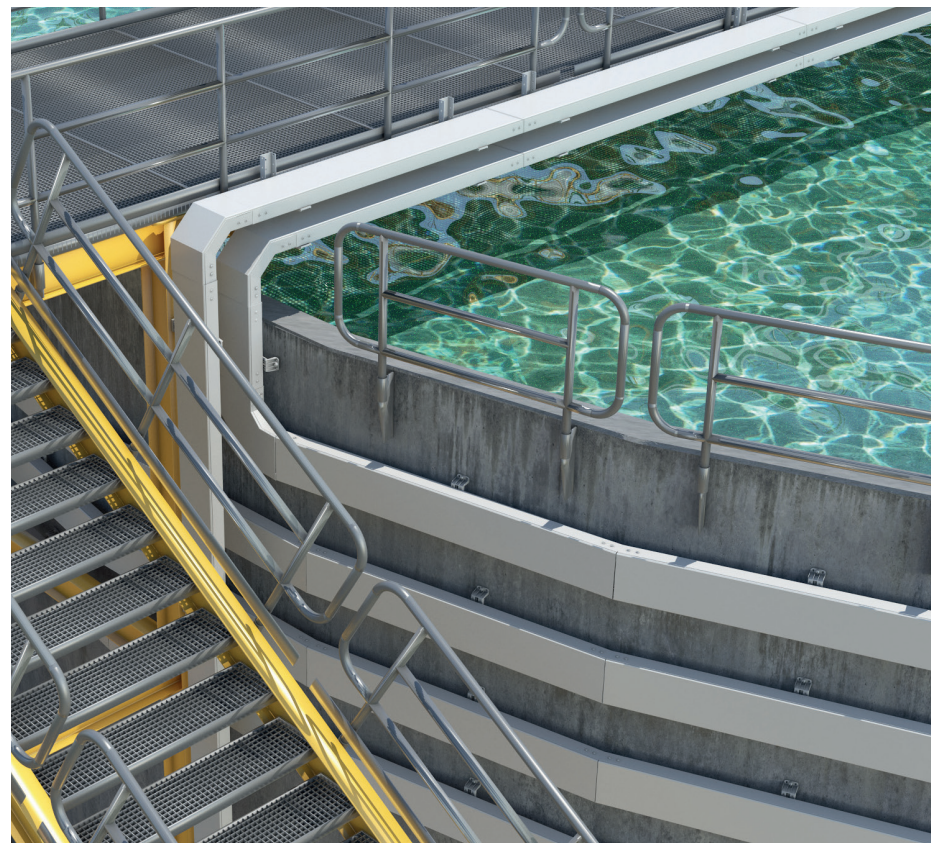

Mining Minería



Mining is the extraction of commercially valuable minerals or other types of geological materials located on land and any non-renewable resource such as oil, natural gas or even water. **The trays manufactured in PVC are the most suitable products given the wet nature of this type of installations, since they present a null affection to the oxidation that occurs in the environment.**

La minería es la extracción de minerales con valor comercial u otros tipos de materiales geológicos ubicados en la tierra y cualquier recurso no renovable como el petróleo, gas natural o incluso agua. **Las bandejas fabricadas en PVC son los productos más convenientes dado la naturaleza húmeda de este tipo de instalaciones, ya que presentan una nula afeción a la oxidación que se produce en el ambiente.**



Chemical industry

Industria química



The chemical industry converts raw materials (oil, natural gas, air, water, metals, and minerals) into more than 70,000 different products through chemical processes. **These chemical environments produce very aggressive atmospheres that affect a lot to the metals, the PVC cable trays are perfect due the big resistance against these aggressive climate.**

La industria química convierte las materias primas (petróleo, gas natural, aire, agua, metales y minerales) en más de 70.000 productos diferentes a través de procesos químicos. **Estos ambientes químicos producen atmósferas muy agresivas que afectan mucho a los metales, las bandejas de PVC son perfectas debido a la gran resistencia contra este clima agresivo.**



Petrochemicals

Also called petroleum distillates, are chemical products derived from petroleum and other fossil fuels, such as coal or natural gas, or renewable sources such as corn or sugar cane. **The processes are made thanks to aggressive distillate that generate humidity environments, the PVC cable trays are the best solution due humidity effects does not impact into the products.**

Petroquímicas

También llamados destilados de petróleo, son productos químicos derivados del petróleo y otros combustibles fósiles, como carbón o gas natural, fuentes renovables como el maíz o la caña de azúcar. **Los procesos se realizan gracias a un destilado agresivo que genera ambientes de humedad, las bandejas de PVC son la mejor solución ya que los efectos de la humedad no repercuten en los productos.**



The pharmaceutical

This industry discovers, develops, produces, and markets drugs or pharmaceutical drugs for use as medications. They are subject to a variety of laws and regulations by the govern about the patenting, testing, safety, efficacy, marketing and production of the drugs. **In the production processes of synthesized drugs with acids, only the non-metal trays as PVC cable trays can be installed thanks to the resistance against acids.**

Farmacéutica

Esta industria descubre, desarrolla, produce y comercializa fármacos para su uso como medicamentos. Están sujetos a una variedad de leyes y regulaciones por parte del gobierno sobre patentes, pruebas, seguridad, eficacia o comercialización. **En los procesos de producción de fármacos sintetizados con ácidos, sólo se pueden instalar las bandejas no metálicas como bandejas de PVC gracias a la alta resistencia frente a ácidos.**



The pulp and paper industry

Comprises companies that use wood as raw material and produce pulp, paper, board and other cellulose based products. The papermaking process has a low environmental impact, while the paper is not bleached. Bleaching requires the use of hydrogen peroxide, or chlorine dioxide, two highly polluting and aggressive substances. **The PVC cable trays are specially designed and formulated to respond to these environments with hardness and durability.**

Industria papelera

Comprende las empresas que utilizan la madera como materia prima y producen pulpa, papel, cartón y otros productos a base de celulosa. El proceso de fabricación del papel tiene un bajo impacto ambiental, mientras que el papel no se blanquee. El blanqueo requiere el uso de peróxido de hidrógeno, o dióxido de cloro, dos sustancias altamente contaminantes y agresivas. **Las bandejas portacable de PVC están especialmente diseñadas y formuladas para responder a estos entornos de alta dureza.**

A fertilizer

A fertilizer is any material of natural or synthetic origin that is applied to soils or to plant tissues to supply one or more plant nutrients essential to the growth of plants. This goal is met in two ways, additives that provide nutrients or modifying the water retention and aeration. **These plants where the fertilizers are made, produce acid and alkaline environments, the PVC cable trays are the best solution due the proven resistance against these environments.**

Plantas de fertilizantes

Un fertilizante es cualquier material de origen natural o sintético que se aplica a los suelos o a los tejidos vegetales para suministrar uno o más nutrientes para el crecimiento de las plantas. Este objetivo se cumple de dos maneras, con aditivos que proporcionan nutrientes o modificando la retención de agua y la aireación. **Las plantas donde se fabrican los fertilizantes, producen ambientes ácidos y alcalinos, las bandejas de PVC son la mejor solución debido a la resistencia demostrada ante estos ambientes.**



Railways infrastructures

Infraestructuras ferroviarias

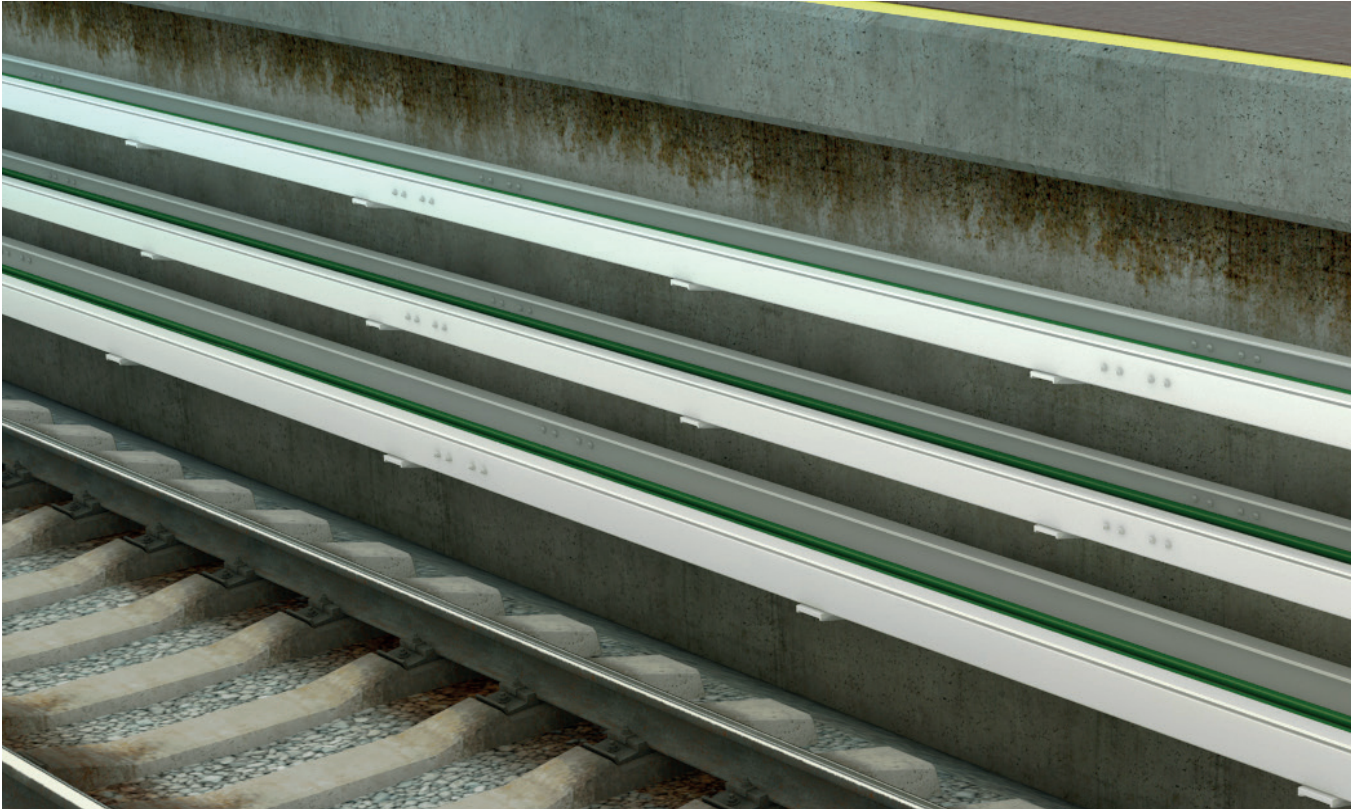

Rail transport is a means of conveyance of passengers and goods on wheeled vehicles running on rails, also known as tracks. It is also commonly referred to as train transport. Tracks, stations, catenaries and substations are the most important infrastructures for the railways industry. **The PVC cable trays are specially designed for outdoor installations as tracks or catenaries and indoor as stations or substations, places where the humidity is high and can affect to the metals.**

El transporte ferroviario es un medio de transporte de pasajeros y mercancías en vehículos de ruedas que circulan sobre carriles, también conocidos como vías. También se refiere comúnmente como transporte en tren. Las vías, estaciones, catenarias y subestaciones son las infraestructuras más importantes para la industria ferroviaria. **Las bandejas de PVC están especialmente diseñadas para instalaciones al aire libre como vías o catenarias e interiores como estaciones o subestaciones, lugares donde la humedad es alta y pueden afectar a los metales.**

Solar installations Instalaciones solares

The solar energy is the energy obtained by the light and heat catchment made by the sun. These installations transform the solar radiation into electrical energy through photovoltaic panels, making possible the accumulation into batteries. All these installations are outdoor, where the inclement weather affect directly. **The PVC cable trays are specially designed to be installed at outdoor environments, having an excellent resistance against the rain and humidity without any kind of oxidation.**

La energía solar es la energía obtenida por la captación de luz y calor hecha por el sol. Estas instalaciones transforman la radiación solar en energía eléctrica a través de paneles fotovoltaicos, posibilitando la acumulación en baterías. Todas estas instalaciones están al aire libre, donde las inclemencias climáticas afectan directamente. **Las bandejas de PVC están especialmente diseñadas para ser instaladas en entornos al aire libre, con una excelente resistencia a la lluvia y a la humedad sin ningún tipo de oxidación.**



Rooftop

A rooftop photovoltaic power station, is a photovoltaic system that has its electricity-generating solar panels mounted on the rooftop of a residential or commercial building or structure, with horizontal or tilted form. **The PVC cable trays are the most fast and practical form to manage the cable installation due the easier to construct the way to the solar panels.**

Azotea

Una central fotovoltaica en la azotea, es un sistema fotovoltaico que tiene sus paneles solares generadores de electricidad montados en el tejado de un edificio residencial o comercial, con forma horizontal o inclinada. **Las bandejas de PVC son la forma más rápida y práctica para gestionar la instalación de los cables debido a que es muy sencillo crear la canalización hacia los paneles solares.**



Solar Farm

A Solar Farm is a photovoltaic power station, with a large-scale photovoltaic system designed for the supply of merchant power into the electricity grid at the utility level, rather than to a local user or users. **The PVC cable trays are the most fast and practical form to manage the cable installation due the easier to construct the way to the solar panels.**

Granja Solar

Una granja solar es una central fotovoltaica, con un sistema fotovoltaico a gran escala diseñado para el suministro de energía comercial en la red eléctrica a nivel de suelo. **Las bandejas de PVC son la forma más rápida y práctica para gestionar la instalación de los cables debido a que es muy sencillo crear la canalización hacia los paneles solares.**

Sea and ports infrastructure

Infraestructuras de mar y puertos



A port infrastructure is a location on a coast or shore containing one or more harbours where ships can dock and transfer people or cargo to or from land. Port locations are selected to optimize access to land and navigable water, for commercial demand, and for shelter from wind and waves. **The PVC trays are perfect to be installed due the salt environments does not affect to the Basorplast.**

Una infraestructura portuaria es una ubicación en la costa donde se alojan los puertos, lugares donde los buques pueden atracar e intercambiar carga o pasajeros desde o hacia tierra. Las localizaciones portuarias están especialmente optimizadas para la protección ante vientos y oleaje y mejorar la navegabilidad y las cargas/descargas de personas y mercancías. **Las bandejas de PVC son perfectas para ser instaladas debido a que los ambientes salinos no afectan al Basorplast.**

Harbour crane

Is a type of machine, generally equipped with a hoist rope, wire ropes or chains, and sheaves, that can be used both to lift and lower materials and to move them horizontally. It is mainly used for lifting heavy things and transporting them to other places. **Cranes are commonly affected by the salty winds, the PVC cable trays are the best solution against the oxidation.**

Grúa Portuaria

Es un tipo de máquina, generalmente equipada con cuerdas de polipasto o cadenas metálicas y poleas, que pueden usarse tanto para elevar elementos pesados y bajar materiales como para moverlos horizontalmente. Se utiliza principalmente para elevar elementos pesados y transportarlas a otros lugares. **Las grúas son comúnmente afectadas por los vientos salados, las bandejas de PVC son la mejor solución contra la oxidación.**



Dam barrier

Is a barrier that impounds water or underground streams. Hydropower is often used in conjunction with dams to generate electricity. **Dams generally are very humid and salt windy areas where the PVC cable trays does not affect it and are the best solution for these kind of works.**

Presa

Es una barrera que impide el paso de agua o arroyos subterráneos. La energía hidroeléctrica usa la fuerza del agua para generar electricidad. Las presas son zonas muy húmedas y se ven afectadas por viento salado. **Las bandejas de PVC no sufren deterioro ante estos elementos y son la mejor solución para estas obras.**

Dock

A dock is either the area of water between or next to a human-made structure or group of structures involved in the handling of boats or ships, usually on or close to a shore, or the structures themselves. **Docks are very humid areas where the PVC cable trays does not affect it and are the best solution for the electrical installations.**

Muelle

Un muelle es el área de agua entre o junto a una estructura o grupo de estructuras, hechas por el hombre y destinadas al atraque de embarcaciones o barcos, generalmente cerca de una orilla. **Los muelles son áreas muy húmedas donde las bandejas de PVC no se ven afectadas y son la mejor solución para las instalaciones eléctricas.**



Boarding Bridge

Is a platform used to the entry the passengers onto a watercraft that can be located in harbour or at sea. Boarding starts with entering of the first passenger and ends with the seating of each passenger and closure of the doors. **Boarding bridges are located at very humid areas where the PVC cable trays does not affect it and are the best solution for the cable management.**

Plataforma de acceso

Es una plataforma utilizada para la entrada de los pasajeros en una embarcación que puede estar situada en puerto o en el mar. El embarque comienza con la entrada del primer pasajero y termina con el asiento de cada pasajero y el cierre de las puertas. **Los puentes de embarque se encuentran en zonas muy húmedas donde las bandejas de PVC no se ven afectadas y son la mejor solución para la gestión de cables.**

Machine building

Construcción de maquinaria



The machine industry is a subsector of the industry, that produces and maintains machines for consumers, the industry, and most other companies in the economy. There are a strong sector for the machinery with water in process. **These machines and its functions, produce humid environments where the PVC cable trays are the correct option to manage the cables installation due its resistance to humidity.**

La industria de construcción de maquinaria es un subsector de la industria, que produce y mantiene las máquinas para los consumidores, la industria y la mayoría de las empresas en la economía. Hay un sector especialmente reseñable que es el de la maquinaria con agua en proceso. **Estas máquinas y sus funciones, producen entornos húmedos donde las bandejas de PVC son la opción correcta para gestionar la instalación de cables debido a su resistencia a la humedad.**

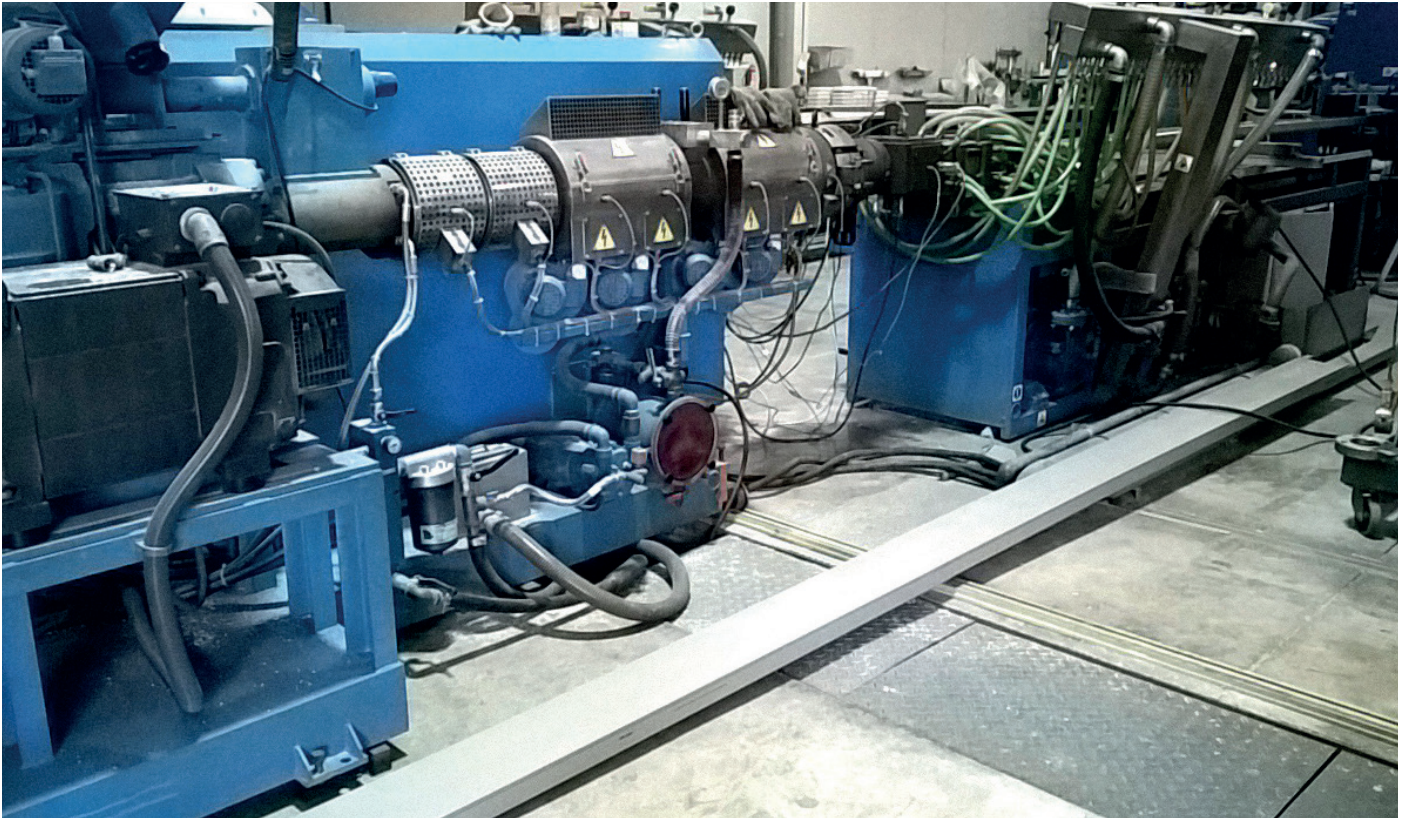

Machinery with water in process, the means of production for businesses in the agriculture, mining, industry and construction or public utility, such as equipment for the production and distribution of gas, electricity and water. A range of supporting equipment for all sectors of the economy, such as equipment for heating, ventilation, and air conditioning of buildings. **The machinery will be installed into a humidity environments, the PVC cable trays are the best solution due the water effects does not impact into the products.**

La maquinaria con agua en proceso es muy común en las empresas de agricultura, minería, industria y construcción así como para la utilidad pública, como equipos para la producción y distribución de gas, electricidad y agua. Se complementa con una gama de equipos de apoyo para todos los sectores de la economía, tales como equipos para calefacción, ventilación y aire acondicionado de edificios. **Esta maquinaria se instala en entornos de humedad, las bandejas de cable de PVC son la mejor solución debido a los efectos del agua no repercute en los productos.**

Shore and cost infrastructure

Infraestructuras costeras y de litoral



Shore or a shoreline is the fringe of land at the edge of a large body of water, such as an ocean, sea, or lake. In physical oceanography, a shore is the wider fringe that is geologically modified by the action of the body of water past and present, while the beach is at the edge of the shore, representing the intertidal zone where there is one. **These kind of areas suffer the effect of the salty winds, the PVC cable trays do not affected by the oxidation that the salt produce in metals, for this reason, is the best option to be installed in front of the sea.**

La costa o el litoral es una franja de tierra en el borde de un gran cuerpo de agua, como un océano, mar o lago. En la oceanografía física, una costa es la franja geológicamente modificada por la acción de la masa de agua, mientras que la orilla está en el borde de la masa de agua. **Este tipo de áreas sufren el efecto de los vientos salados, las bandejas de PVC no se ven afectadas por la oxidación que produce la sal en los metales, por esta razón, es la mejor opción para instalarse frente al mar.**



HOTEL

A hotel is an establishment that provides lodging paid on a short-term basis. Facilities provided may range from a modest-quality mattress in a small room to large suites. The hotels located at beach areas or near from the sea, are affected directly by the humid and the salty winds every day. **The PVC cable trays are specially designed to not be affected by these situation, being the best option for this kind of installation.**

HOTEL

Un hotel es un establecimiento que ofrece alojamiento pagado a corto plazo. Las instalaciones pueden variar desde un alojamiento de calidad modesta en una habitación pequeña a grandes suites. Los hoteles situados en las zonas de playa o cerca del mar, se ven afectados directamente por los vientos húmedos y salados todos los días. **Las bandejas de PVC están especialmente diseñadas para no verse afectadas por esta situación, siendo la mejor opción para este tipo de instalación.**



TERTIARY BUILDING

A commercial or tertiary building is a building that is used for commercial use. Types can include office buildings, warehouses, or retail. In beach locations, a commercial building often combines functions, such as an apartments on levels 2-10, with retail on floor 1. The buildings located at beach areas or near from the sea, are affected directly by the humid and the salty winds every day. **The PVC cable trays are specially designed to not be affected by these situation, being the best option for this kind of installation.**

EDIFICIOS TERCIARIOS

Un edificio comercial o terciario es un edificio que se utiliza para uso comercial. Pueden incluir edificios de oficinas, almacenes, o venta al por menor. En los lugares de playa, un edificio comercial a menudo combina funciones tales como apartamentos en los niveles 2-10, con venta al por menor en las plantas bajas. Los edificios situados en las zonas de playa o cerca del mar, se ven afectados directamente por los vientos húmedos y salados cada día. **Las bandejas de PVC están especialmente diseñadas para no verse afectadas por esta situación, siendo la mejor opción para este tipo de instalación.**

Metal chemical industry

Industria química metálica



The production of metals involves the chemical processing to extract the metal that contain, and the mixture of metals, sometimes with other elements to produce alloys. **These process are highly aggressive due the sulphur generated, the PVC cable trays are the most convenient solution thanks to the big resistance against it.**

La producción de metales implica el procesamiento químico para extraer el metal que contiene una materia prima así como otros elementos para producir aleaciones. **Estos procesos son muy agresivos debido al azufre generado, las bandejas de PVC son la solución más conveniente gracias a la gran resistencia contra este elemento.**



Metallurgy

Is a domain of materials science and engineering that studies the physical and chemical behaviour of metallic elements, their intermetallic compounds, and their mixtures, which are called alloys. The production of metals involves chemical processing to produce alloys. **These processes produce zinc and lead atmospheres, the PVC cable trays are designed to hold on these environments with a long life.**

Metalúrgica

La metalurgia es la ciencia de los materiales cuya ingeniería estudia el comportamiento físico y químico de los elementos metálicos, sus compuestos intermetálicos, y sus mezclas (llamadas aleaciones). La producción de metales implica procesamiento químico para producir aleaciones.

Estos procesos producen ambientes de zinc y plomo. **Las bandejas de PVC están diseñadas para soportar en estos entornos con una larga vida útil.**

Electrolytic Refining

An electrolytic process is the use of electrolysis industrially to refine metals or compounds at a high purity and low cost. Some examples are the Hall-Héroult process used for aluminium, or the production of hydrogen from water. **These processes generate humidity environments, the PVC cable trays does not affect it and are the best solution for these works.**

Refinamiento electrolítico

Un proceso electrolítico es el uso de electrólisis industrial para refinar metales o compuestos con una alta pureza y bajo coste. Algunos ejemplos son el proceso Hall-Héroult usado para el aluminio, o la producción de hidrógeno a partir del agua. **Estos procesos generan ambientes de humedad, las bandejas de PVC no se ven afectadas y son la mejor solución para estos trabajos.**



Other auxiliary processes:

- **Natural-gas** processing is a complex industrial process designed to clean raw natural gas by separating impurities and various non-methane hydrocarbons and fluids to produce what is known as pipeline quality dry natural gas.
- **Electroslag remelting (ESR)**, also known as electro-flux remelting, is a process of remelting and refining steel and other alloys for mission-critical applications in aircraft, thermal power stations, nuclear power plants, military technology... **The PVC cable trays are the best solution for the gas and electroslag environments due to its high resistance to the gas and remelting effects.**

Otros procesos auxiliares:

- El procesamiento de **gas natural** es un complejo proceso industrial diseñado para limpiar el gas natural bruto mediante la separación de impurezas y varios hidrocarburos y fluidos no metánicos para producir lo que se conoce como gas natural seco de gasoducto.
- **La refusión electrostática (ESR)**, también conocida como refundición de electrofusión, es un proceso de refundición y refinado del acero y otras aleaciones para aplicaciones en aviones, centrales térmicas, centrales nucleares, tecnología milita... **El PVC como material de fabricación en las bandejas es la mejor solución para los ambientes de gas y refusión debido a su alta resistencia al gas ya los efectos de refundición.**



- **A cooling tower** is a heat rejection device that rejects waste heat to the atmosphere through the cooling of a water stream to a lower temperature.
- **A galvanization plant** or treatment plant is a common place to put extra coatings to the metals. These processes produce vapours and aggressive environments.

The PVC cable trays are the most convenient material for vapour atmosphere thanks to the good behaviour at humid environments.

- **Una torre de enfriamiento** es un dispositivo de rechazo de calor que vierte cierto calor residual a la atmósfera gracias a un proceso de enfriamiento mediante una corriente de agua a una temperatura más baja.
- **Una planta de galvanización** o una planta de tratamiento es un lugar para poner recubrimientos adicionales a los metales. Estos procesos producen vapores y ambientes agresivos.

Las bandejas de PVC son el material más conveniente para la atmósfera de vapor gracias al buen comportamiento en ambientes de este estilo.

Products that the PVC tray can replace

Productos que el PVC puede reemplazar

The PVC cable trays can replace other materials with a high resistance against the corrosion, salinity or humidity like **Fiberglass, stainless steel 304, stainless steel 316 or aluminum.**

Las bandejas de PVC pueden reemplazar otros materiales con alta resistencia ante corrosión, salinidad o humedad. **Como fibra de vidrio, acero inoxidable 304, acero inoxidable 316 o aluminio.**



Main Advantages:

Excellent corrosion behavior for chemical and saline environment

Electrical safety: Insulating material, earthing not required. Specially important in installations in areas where there are access for people. In a metal tray with a bad grounding, or coincide in the middle of 2 crossbeams, is potentially dangerous if it is touched. Due the pvc trays are insulating, these situations are not danger, even if there are a bare wire inside, the tray remains secure if you touch it.

Avoids creepage, hot spots and electrical arcs.

Good performance outdoors and to corrosion, over 40 years experience in outdoor installations.

No maintenance.

	ADVANTAGES	DISADVANTAGES
FiberGlass Cable Tray, Cable Ladder	Cost efficient	Lowest admissible working load
	Equal or better chemical behavior	
	Self extinguising	Greater limitation of working temperatures
	Recyclable	
	Weithg Product for comfort installation.	
Stainless Steel Cable Tray, Cable Ladder	Major Electrical Safety of the installation, does not have electrical continuity	Lowest admissible working load
	Cost efficient	Greater limitation of working temperatures
	Facing SS304 better performance in saline environment	
Aluminium Cable Tray and Cable Ladder	Major Electrical Safety of the installation, does not have electrical continuity	Lowest admissible working load
	Cost efficient	
	Best corrosion behavior for aluminum (NO Anodized, 100% welding cable ladders)	Greater limitation of working temperatures

Principales ventajas

Excelente comportamiento ante la corrosión química y los ambientes salinos

Seguridad eléctrica: Material aislante, no requiere toma tierra. Especialmente importante para instalaciones en áreas donde las personas puedan tener acceso. En bandejas metálicas con toma tierra instalada de manera deficiente o en el cruce de dos bandejas, existe un potencial peligro eléctrico si se toca el material. Por el contrario, las bandejas de PVC son aislantes, este tipo de situaciones no son un peligro para el consumidor, incluso habiendo cables pelados en su interior, la bandeja continua siendo segura aunque se toque.

Evita fugas, puntos calientes y arcos eléctricos

Buen comportamiento al exterior y la corrosión, más de 40 años de experiencia en instalaciones al aire libre

Sin mantenimiento

	VENTAJAS	DESVENTAJAS
Bandejas y escaleras de fibra de vidrio	Más eficiente en coste	Menor carga de trabajo admisible
	Igual o mejor comportamiento ante ambientes químicos	
	Auto-extinguible	Mayor limitación en altas temperaturas de trabajo
	Reciclable	
	Peso del producto permite una instalación más confortable	
Bandejas y escaleras de acero inoxidable	Mayor seguridad eléctrica en la instalación dado que no tiene continuidad eléctrica	Menor carga de trabajo admisible
	Más eficiente en coste	Mayor limitación en altas temperaturas de trabajo
	De cara a aceros 304, tiene un mejor resultado en ambientes salinos	
Bandejas y escaleras de aluminio	Mayor seguridad eléctrica en la instalación dado que no tiene continuidad eléctrica	Menor carga de trabajo admisible
	Más eficiente en coste	
	Mejor comportamiento ante la corrosión del aluminio (No anodizado, 10096 para soldaduras en escalera)	Mayor limitación en altas temperaturas de trabajo

Cutting Corte

- i** Basorplast cable tray is made from a PVC material that can be cut using a standard hand cutting saw with a fine-tooth cutting blade.

Lightly sand any rough surfaces for optimum results.

Las bandejas Basorplast están fabricadas en PVC el cual puede ser cortado con una sierra manual estándar que tenga una hoja de dientes finos.

Lijar las superficies rugosas para obtener resultados óptimos.

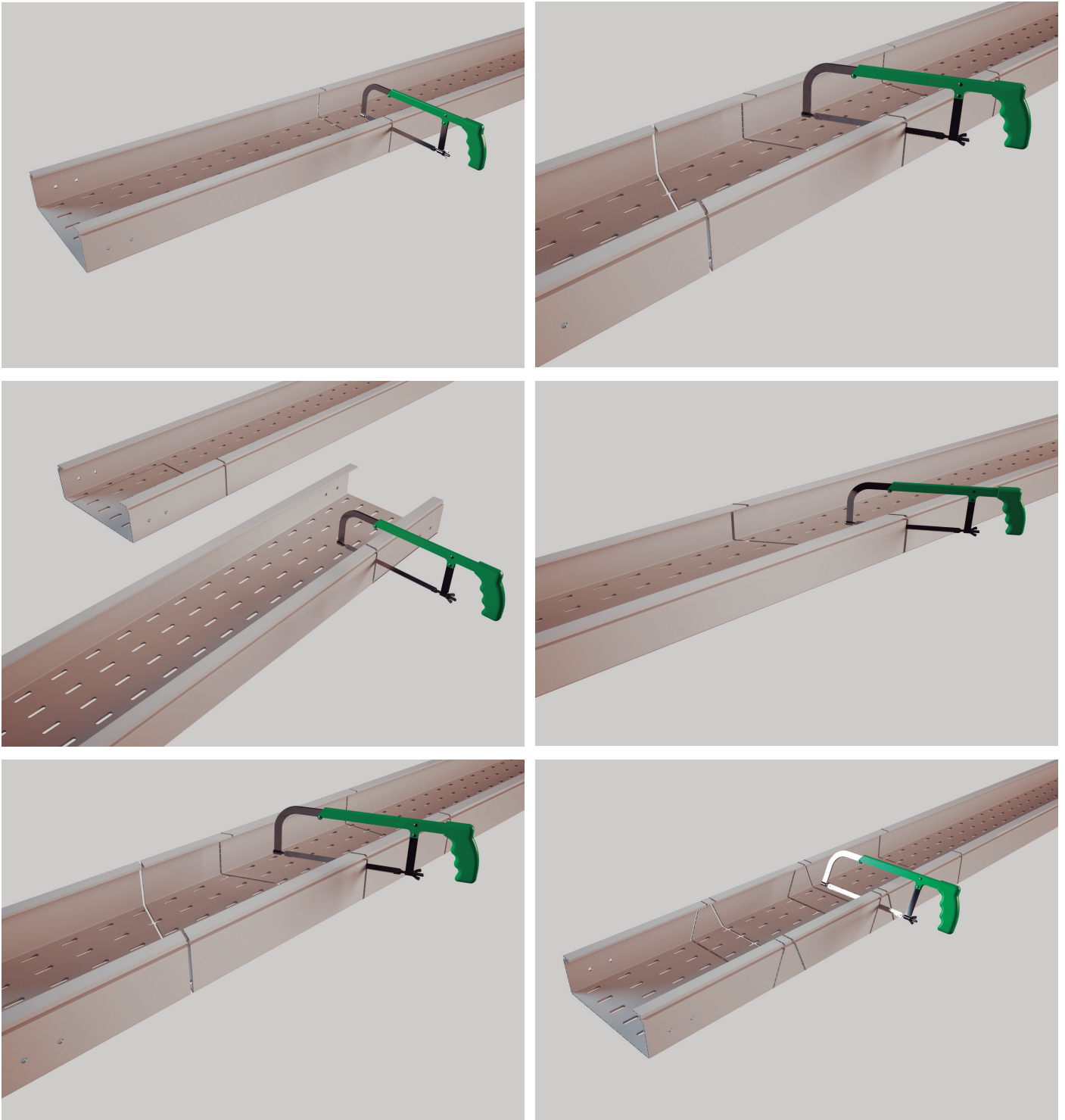

Tools and mounting accessories Herramientas y accesorios de montaje

Mounting accessories / Accesorios de montaje



Screws and nuts:

PVC sets of screws and nuts for all the list of union joints (2/10017).

Tornillos y tuercas:

Conjuntos de tornillos y tuercas en PVC para todo tipo de juntas de unión (2/10017).



Standard union joint:

Straight PVC union joint available for high 60 (2/10084) and high 100 (2/10085).

Juntas de unión estándar:

Juntas de unión rectas fabricadas en PVC disponibles para altura 60 (2/10084) y altura 100 (2/10085).

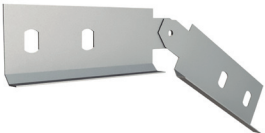

Vertical union joint:

Articulated painted stainless steel 304 union joint available for high 60 (2/5036) and high 100 (2/5037).

Junta de unión vertical:

Juntas de unión articuladas fabricadas en acero inoxidable pintado 304, disponibles para altura 60 (2/5036) y altura 100 (2/5037).

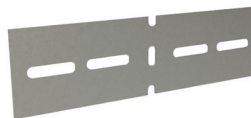

Horizontal union joint:

Movable painted stainless steel 304 union joint available for high 60 (2/3520) and high 100 (2/5038).

Junta de unión horizontal:

Juntas de unión curvables fabricadas en acero inoxidable pintado 304 para altura 60 (2/3520) y altura 100 (2/5038).



Derivation Piece:

Angle made of pre-galvanized painted metal standard for high 60 and high 100 (2/10127).

Pieza de derivación:

Ángulos fabricados en material pre-galvanizado pintado para altura 60 y 100 (2/10127).

Tools / Herramientas



Electric Drill:

Use an electric drill machine and a borer to drill (of the n°8)

Taladro eléctrico:

Usar un taladro eléctrico y una broca para agujerear (broca del n°8).



Cutting saw:

Use an standard cutting saw for PVC materials.

Sierra de mano:

Usar una sierra manual estándar para corte de plástico.



De-Burr Machine:

Use an small hand re-burr cutter for all materials.

Rebabadora:

Usar una pequeña rebabadora manual para todo tipo de materiales.

Straight Junctions Uniones rectas

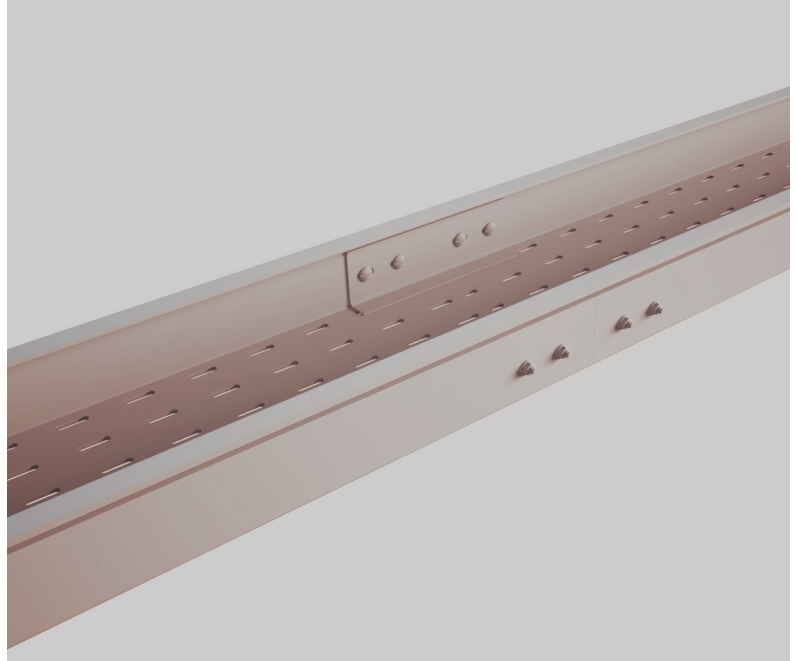
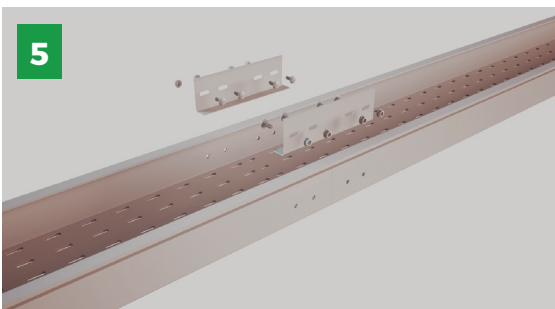
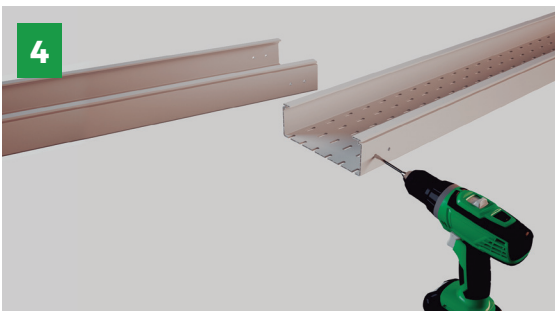
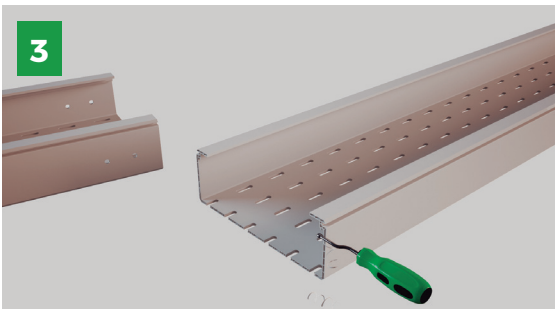
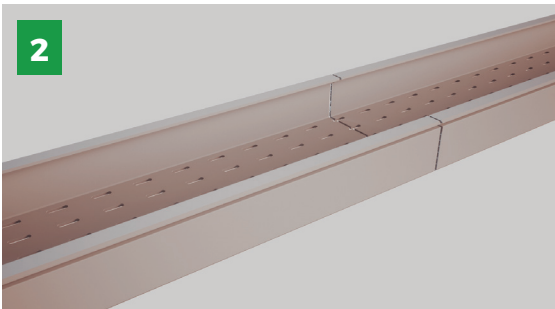
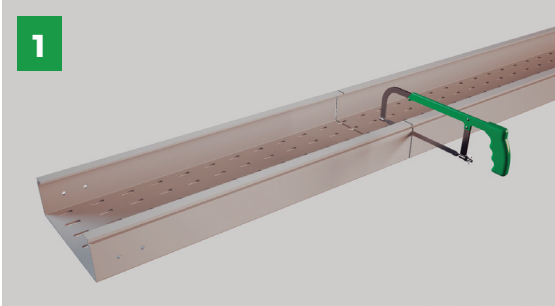

INSTRUCTIONS / INSTRUCCIONES

EN

1. Cut the tray piece with the cutting saw into 2 pieces making a straight cut.
2. Separate the 2 pieces.
3. Remove any rough edges with the de-burring machine.
4. Make 2 holes (for high 60) or 4 holes (for high 100) on each piece with the electric drill.
5. Put 2 union joints JUBPE (2/10084 for the 60mm height or 2/10085 for the 100mm) in the correct position and fix the union joints on the tray using 4 screws (for high 60) or 8 screws (for high 100) B2-P (2/10017).

ES

1. Cortar en dos trozos la bandeja con una sierra de mano mediante un corte recto.
2. Separar las dos piezas.
3. Quitar las superficies rugosas con una rebabadora.
4. Hacer 2 agujeros (para altura 60) o 4 agujeros (para altura 100) en cada pieza con un taladro.
5. Poner 2 juntas de unión JUBPE (código 2/10084 para altura 60 o código 2/10085 para altura 100) en la posición correcta y fija cada una de ellas a la bandeja con sus respectivos tornillos y tuercas B2-P (código 2/10017, 2 unidades para altura 60 o 4 para altura 100).

Horizontal Bends / Small Radius Curvas planas / Radio corto

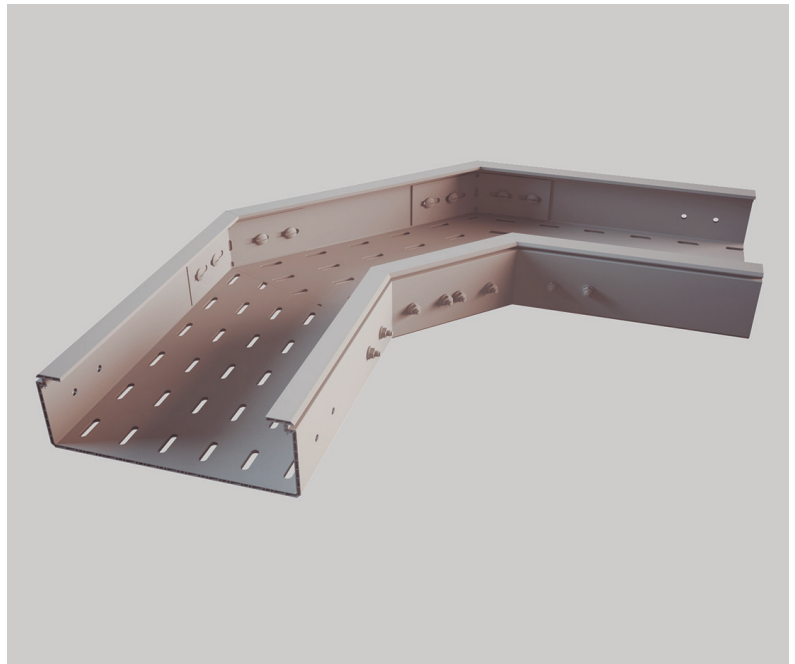
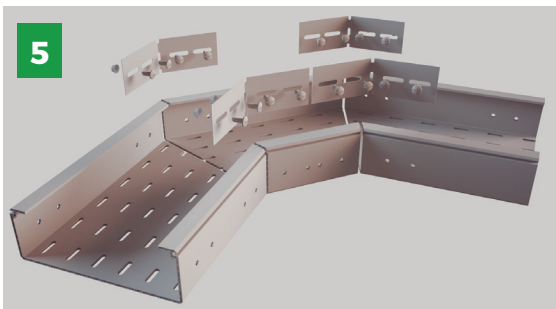
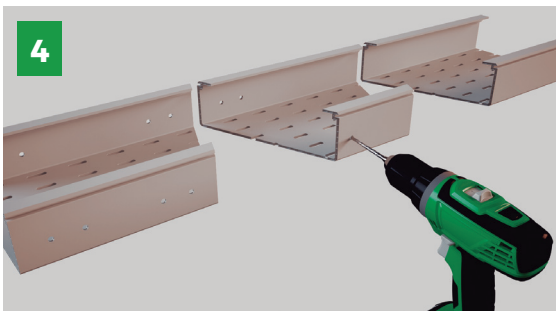
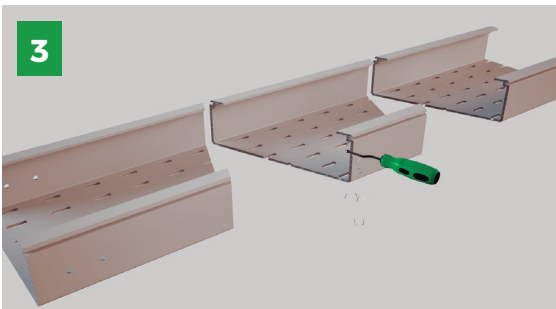
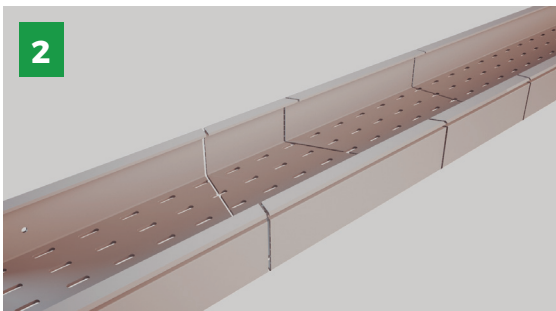
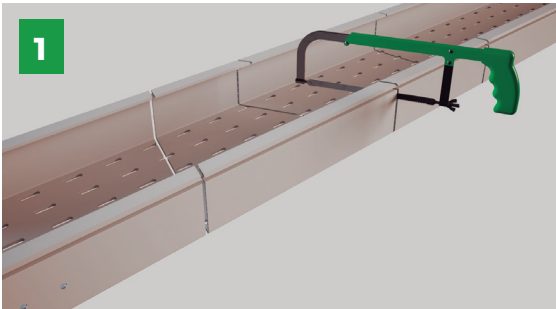

INSTRUCTIONS / INSTRUCCIONES

EN

1. Cut the tray piece with the cutting saw in 3 pieces making a 45° cut.
2. Separate the 3 pieces.
3. Remove any rough edges with the de-burring machine.
4. Make 8 holes on each piece with the electric drill.
5. Put 4 union joints JUBPE-B (2/3520 for the 60mm height or 2/5038 for the 100mm) in the correct position and fix the union joints on the tray using 16 screws B2-P (2/10017).

ES

1. Cortar la bandeja en tres trozos a 45° con una sierra de mano.
2. Separar las tres piezas.
3. Quitar las superficies rugosas con una rebabadora .
4. Hacer 8 agujeros en cada pieza con un taladro eléctrico.
5. Poner 4 juntas de unión JUBPE-B (2/3520 para altura 60 o 2/5038 para altura 100) en la posición correcta y fija cada una de ellas a la bandeja con 4 tornillos y 4 tuercas B2-P (2/10017), usando en total 16 tornillos y 16 tuercas.

Horizontal Bends / Right Radius Curvas planas / Radio recto

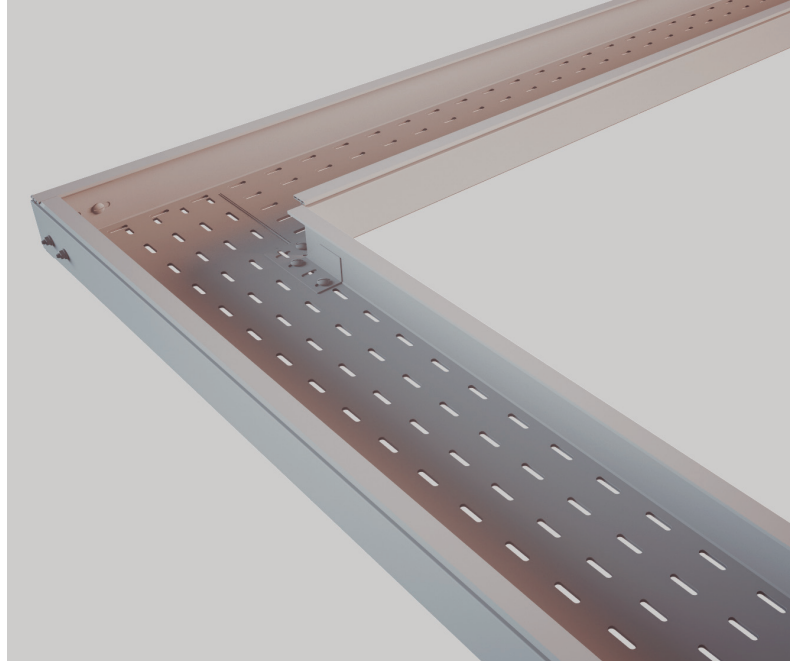
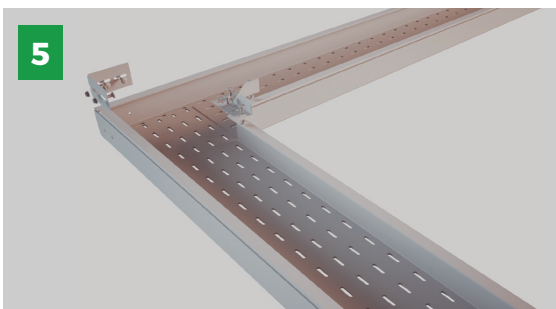
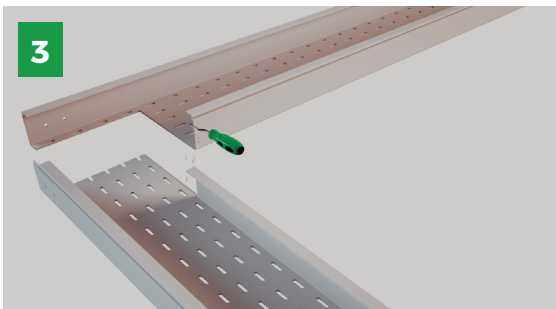
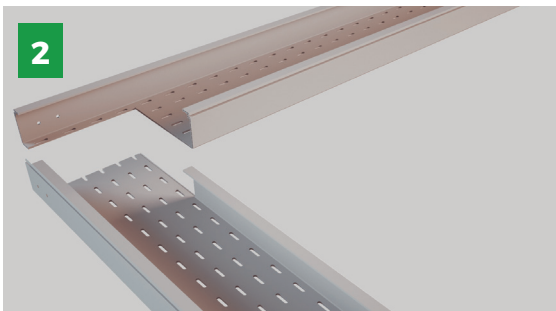
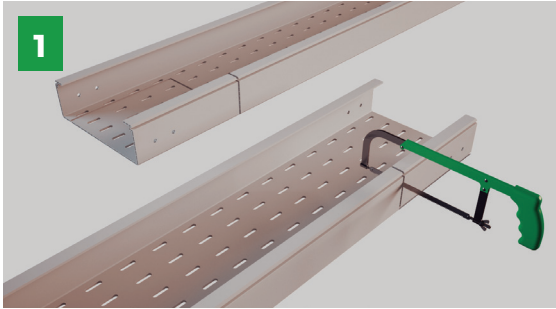

INSTRUCTIONS / INSTRUCCIONES

EN

1. Cut the tray piece 1 removing the base and cut the tray piece 2 removing the side body, both with the cutting saw.
2. Separate the 2 pieces.
3. Remove any rough edges with the de-burring machine.
4. Make 4 holes on each piece with the electric drill.
5. Put 1 union joint JUBPE-B (2/3520 for the 60mm height or 2/5038 for the 100mm) and 1 PDBPE(2/10127) in the correct position and fix the union joints on the tray using 8 screws B2-P (2/10017).

ES

1. Cortar la bandeja número 1 quitando la base, corta la bandeja número 2 quitando el ala, ambas dos con una sierra de mano.
2. Separar las dos piezas.
3. Quitar las superficies rugosas con una rebabadora.
4. Hacer 4 agujeros en cada pieza con un taladro eléctrico.
5. Poner 1 junta de unión JUBPE-B (2/3520 para altura 60 o 2/5038 para altura 100) y 1 pieza de derivación PDBPE (2/10127) en la posición correcta, fija cada una de ellas a la bandeja con 4 tornillos y 4 tuercas B2-P (2/10017), usando en total 8 tornillos y 8 tuercas.

Horizontal Bends / Large Radius Curvas planas / Radio largo

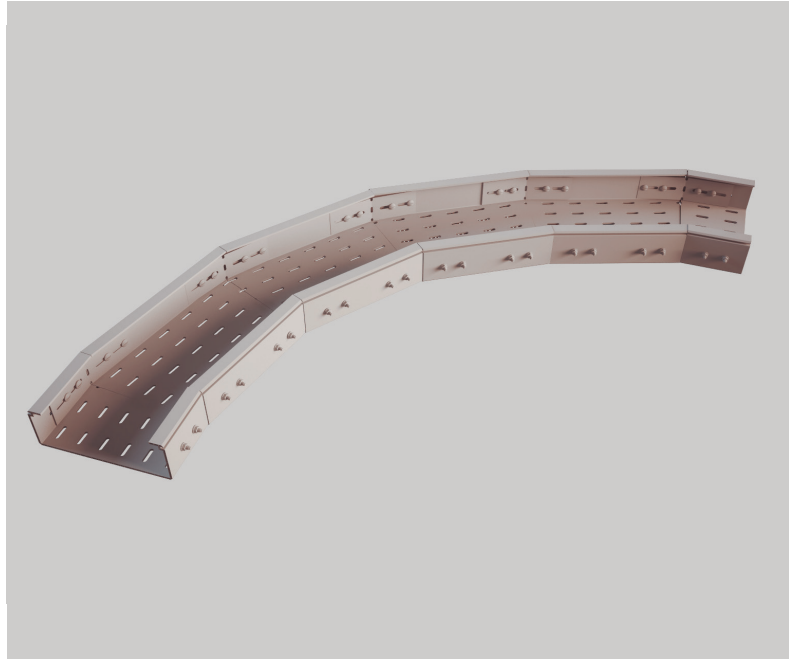
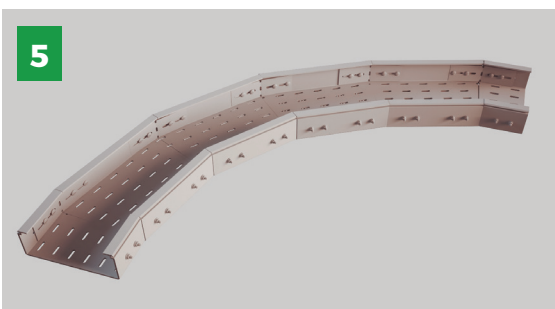
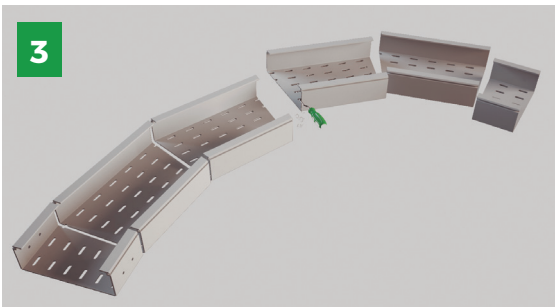
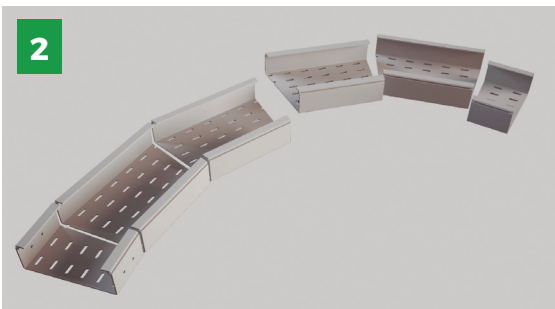
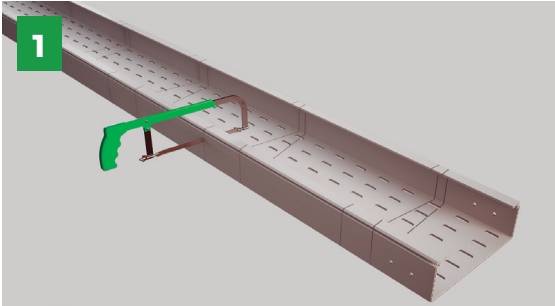

INSTRUCTIONS / INSTRUCCIONES

EN

1. Cut the tray piece with the cutting saw in 6 pieces making a 45° cut.
2. Separate the 6 pieces.
3. Remove any rough edges with the de-burring machine.
4. Make 4 holes on each piece with the electric drill.
5. Put 10 union joints JUBPE-B (2/3520 for the 60mm or 2/5038 for the 100mm) in the correct position and fix the union joints on the tray using 40 screws B2-P (2/10017).

ES

1. Cortar la bandeja en seis trozos a 45° con una sierra de mano.
2. Separar las seis piezas.
3. Quitar las superficies rugosas con una rebabadora.
4. Hacer 4 agujeros en cada pieza con un taladro eléctrico.
5. Poner 10 juntas de unión JUBPE-B (2/3520 para altura 60 o 2/5038 para altura 100) en la posición correcta, fija cada una de ellas a la bandeja con 4 tornillos y 4 tuercas B2-P (2/10017), usando en total 40 tornillos y 40 tuercas.

Horizontal Bends / Other Radius Curvas planas / Otros radios

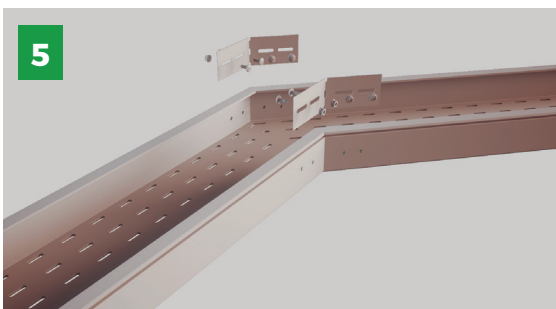
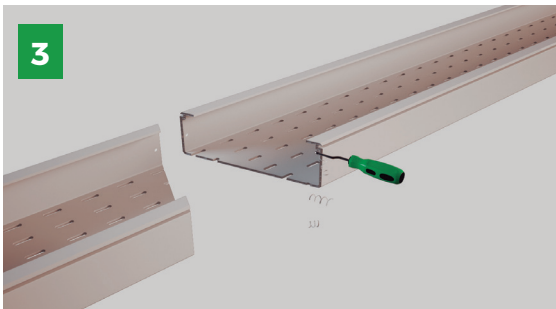
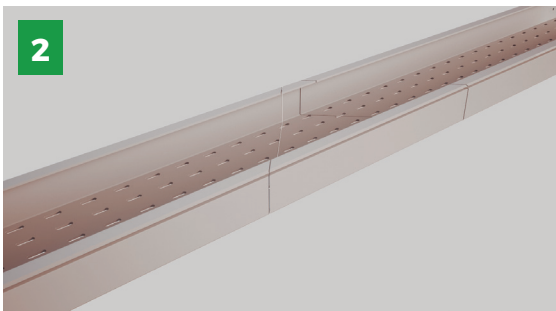
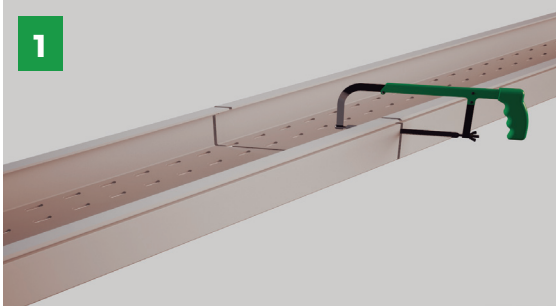

INSTRUCTIONS / INSTRUCCIONES

EN

1. Cut the tray piece with the cutting saw in 2 pieces making a 45° cut.
2. Separate the 2 pieces.
3. Remove any rough edges with the de-burring machine.
4. Make 4 holes on each piece with the electric drill.
5. Put 2 union joints JUBPE-B (2/3520 for the 60mm or 2/5038 for the 100mm) in the correct position and fix the union joints on the tray using 8 screws B2-P (2/10017).

ES

1. Cortar la bandeja en dos trozos a 45° con una sierra de mano.
2. Separar las dos piezas.
3. Quitar las superficies rugosas con una rebabadora .
4. Hacer 4 agujeros en cada pieza con un taladro eléctrico.
5. Poner 2 juntas de unión JUBPE-B (2/3520 para altura 60 o 2/5038 para altura 100) en la posición correcta, fija cada una de ellas a la bandeja con 4 tornillos y 4 tuercas B2-P (2/10017), usando en total 8 tornillos y 8 tuercas.

Inside Bends / Small radius Curvas cóncavas / Radio corto

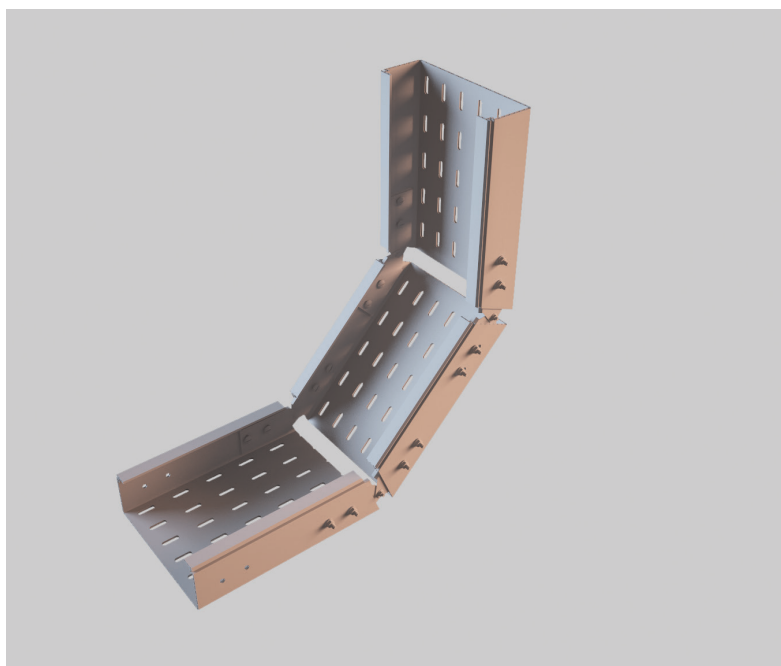
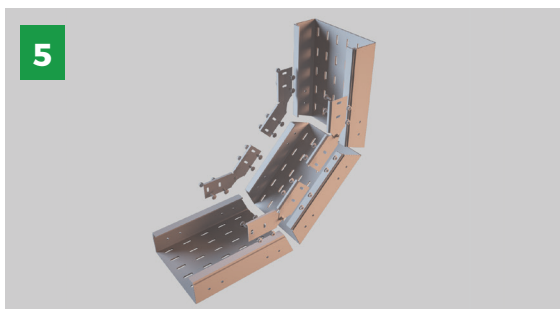
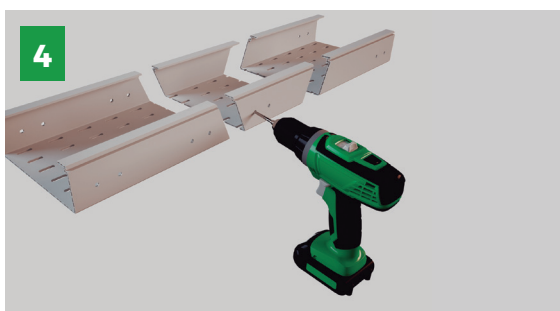
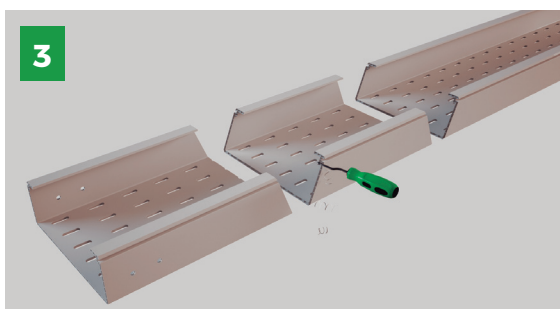
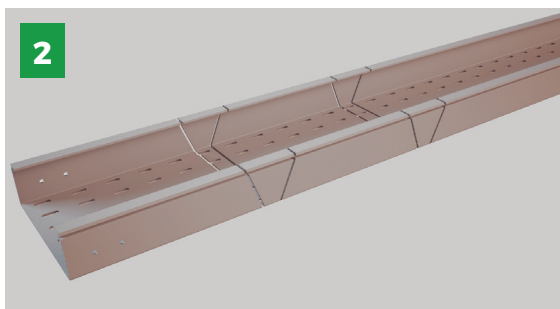
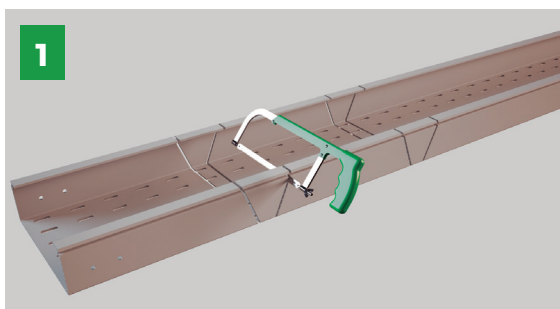

INSTRUCTIONS / INSTRUCCIONES

EN

1. Cut the tray piece with the cutting saw in 3 pieces making a 45° angle cut.
2. Separate the 3 pieces.
3. Remove any rough edges with the de-burring machine.
4. Make 4 holes on each piece with the electric drill.
5. Put 4 union joints JUBPE-A (2/5036 for the 60mm or 2/5037 for the 100mm) in the correct position and fix the union joints on the tray using 16 screws B2-P (2/10017).

ES

1. Cortar la bandeja inclinada en tres trozos a 45° con una sierra de mano.
2. Separar las tres piezas.
3. Quitar las superficies rugosas con una rebabadora .
4. Hacer 4 agujeros en cada pieza con un taladro eléctrico.
5. Poner 4 juntas de unión JUBPE-A (2/5036 para altura 60 o 2/5037 para altura 100) en la posición correcta, fija cada una de ellas a la bandeja con 4 tornillos y 4 tuercas B2-P (2/10017), usando en total 16 tornillos y 16 tuercas.

Inside Bends / Right radius Curvas cóncavas / Radio recto

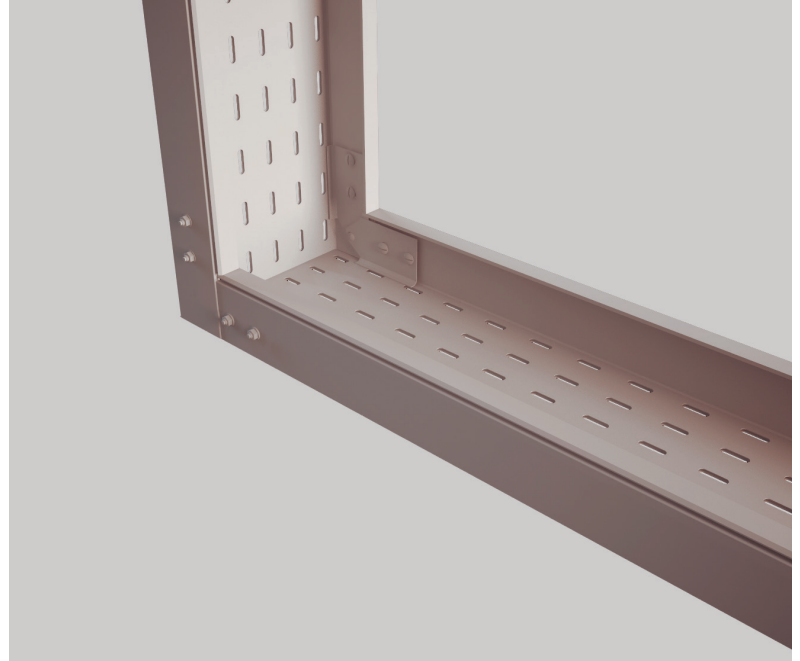
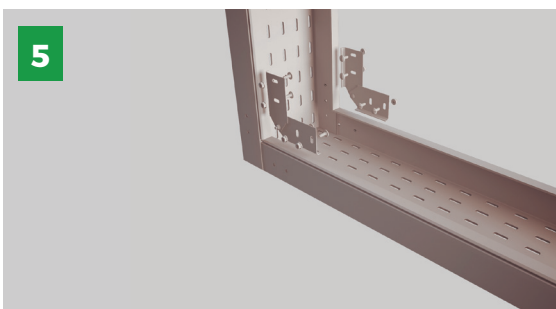
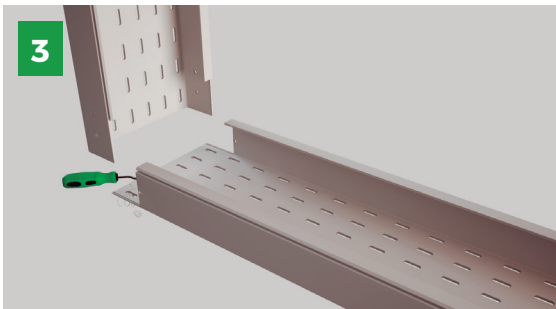
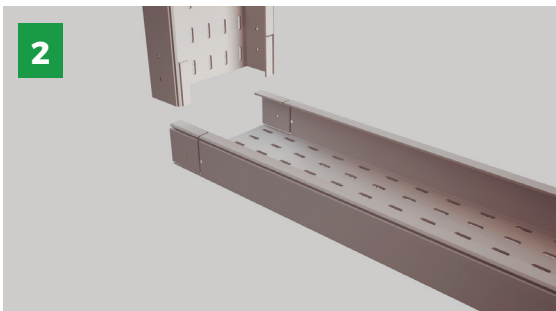
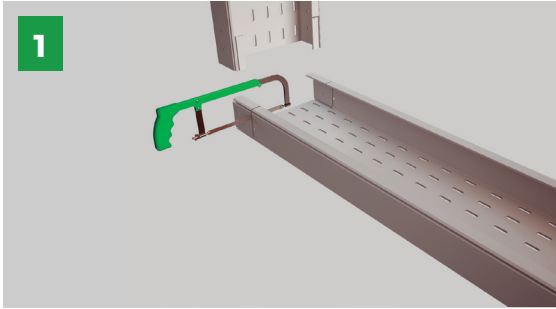

INSTRUCTIONS / INSTRUCCIONES

EN

1. Cut the tray piece 1 removing the top side body and cut the tray piece 2 removing the side body, both with the cutting saw.
2. Separate the 2 pieces.
3. Remove any rough edges with the de-burring machine.
4. Make 4 holes on each piece with the electric drill.
5. Put 2 union joints JUBPE-A (2/5036 for the 60mm or 2/5037 for the 100mm) in the correct position and fix the union joints on the tray using 8 screws B2-P (2/10017).

ES

1. Cortar la bandeja número 1 quitando el ala superior, corta la bandeja número 2 quitando el ala lateral, ambas dos con una sierra de mano.
2. Separar las dos piezas.
3. Quitar las superficies rugosas con una rebabadora.
4. Hacer 4 agujeros en cada pieza con un taladro eléctrico.
5. Poner 2 juntas de unión JUBPE-A (2/5036 para altura 60 o 2/5037 para altura 100) en la posición correcta, fija cada una de ellas a la bandeja con 4 tornillos y 4 tuercas B2-P (2/10017), usando en total 8 tornillos y 8 tuercas.

Inside Bends / Large radius Curvas cóncavas / Radio largo

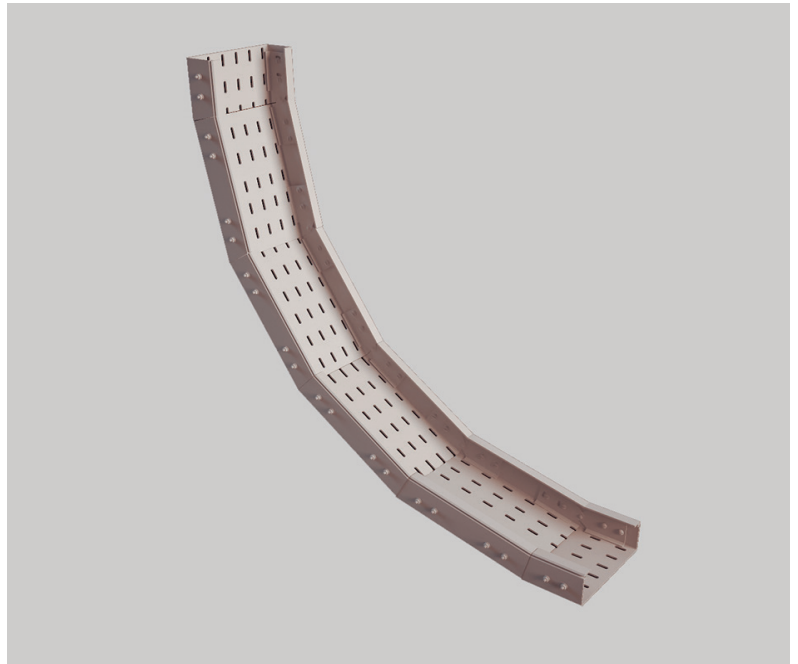
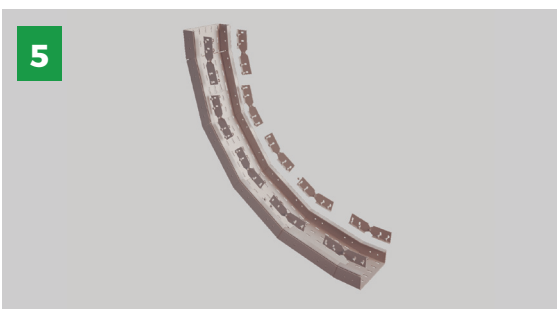
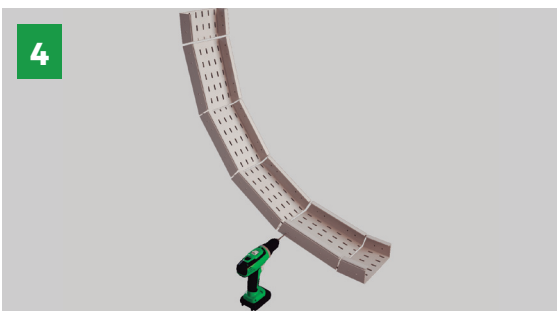
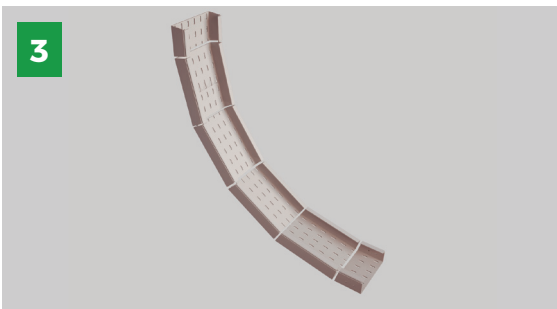
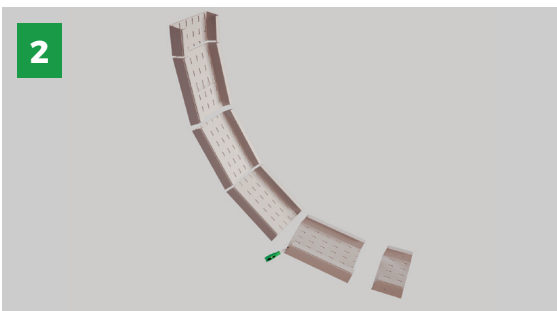
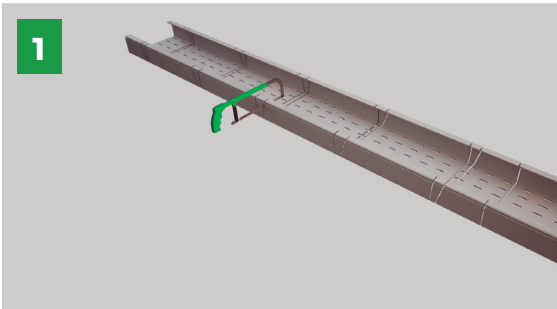

INSTRUCTIONS / INSTRUCCIONES

EN

1. Cut the tray piece with the cutting saw in 6 pieces making a 45° angle cut.
2. Separate the 6 pieces.
3. Remove any rough edges with the de-burring machine.
4. Make 4 holes on each piece with the electric drill.
5. Put 10 union joints JUBPE-A (2/5036 for the 60mm or 2/5037 for the 100mm) in the correct position and fix the union joints on the tray using 40 screws B2-P (2/10017).

ES

1. Cortar la bandeja inclinada en seis trozos a 45° con una sierra de mano.
2. Separar las seis piezas.
3. Quitar las superficies rugosas con una rebabadora .
4. Hacer 4 agujeros en cada pieza con un taladro eléctrico.
5. Poner 10 juntas de unión JUBPE-A (2/5036 para altura 60 o 2/5037 para altura 100) en la posición correcta, fija cada una de ellas a la bandeja con 4 tornillos y 4 tuercas B2-P (2/10017), usando en total 40 tornillos y 40 tuercas.

Outside Bends / Small radius Curvas convexas / Radio corto

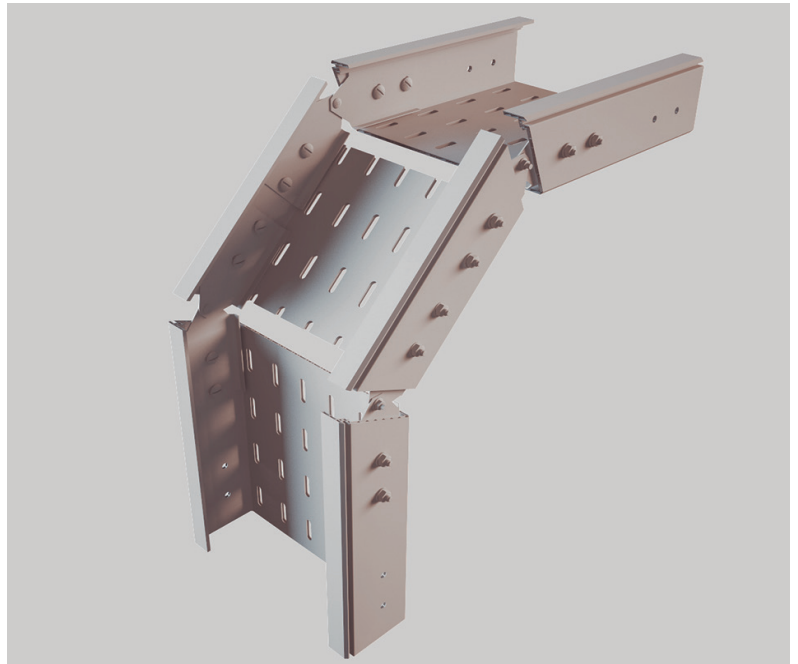
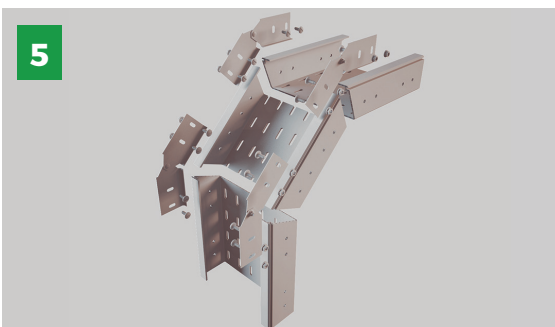
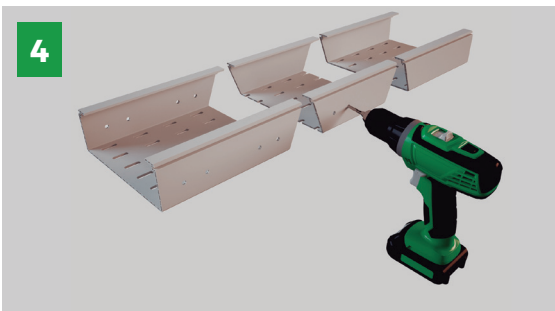
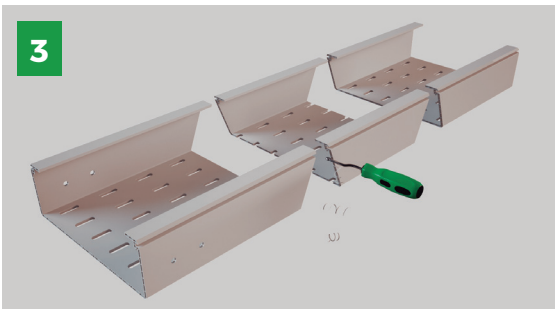
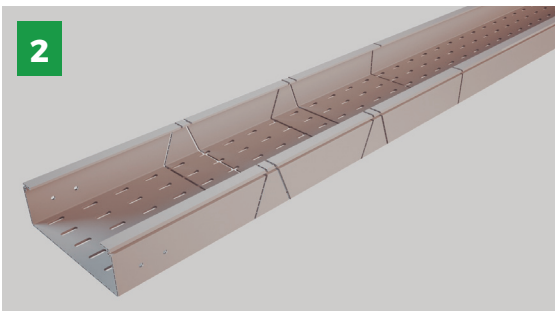
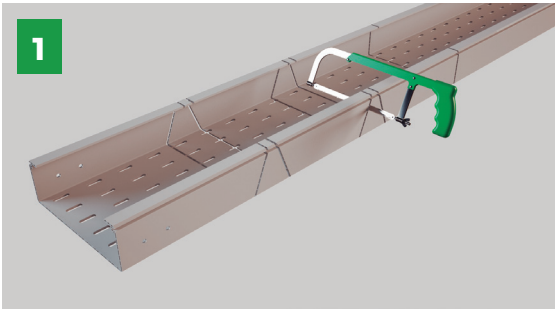

INSTRUCTIONS / INSTRUCCIONES

EN

1. Cut the tray piece with the cutting saw in 3 pieces making a 45° angle cut.
2. Separate the 3 pieces.
3. Remove any rough edges with the de-burring machine.
4. Make 4 holes on each piece with the electric drill.
5. Put 4 union joints JUBPE-A (2/5036 for the 60mm or 2/5037 for the 100mm) in the correct position and fix the union joints on the tray using 16 screws B2-P (2/10017).

ES

1. Cortar la bandeja inclinada en 3 trozos a 45° con una sierra de mano.
2. Separar las 3 piezas.
3. Quitar las superficies rugosas con una rebabadora.
4. Hacer 4 agujeros en cada pieza con un taladro eléctrico.
5. Poner 4 juntas de unión JUBPE-A (2/5036 para altura 60 o 2/5037 para altura 100) en la posición correcta, fija cada una de ellas a la bandeja con 4 tornillos y 4 tuercas B2-P (2/10017), usando en total 16 tornillos y 16 tuercas.

Outside Bends / Right radius Curvas convexas / Radio recto

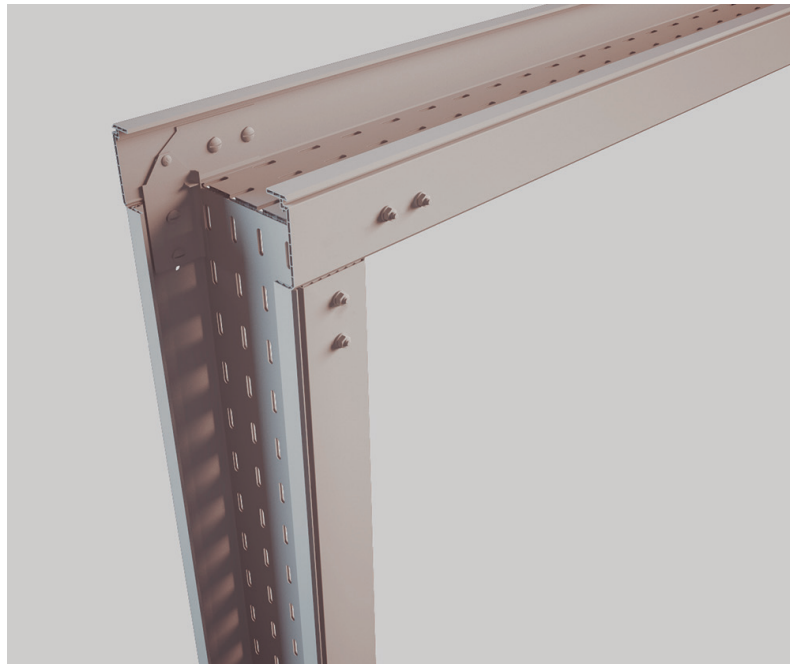
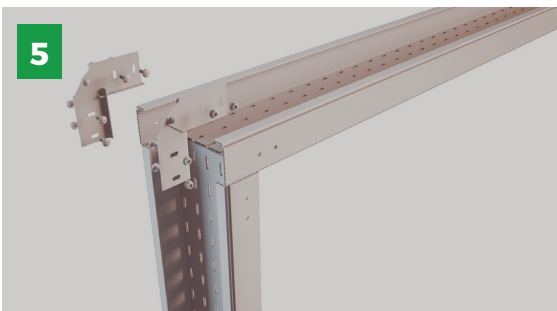
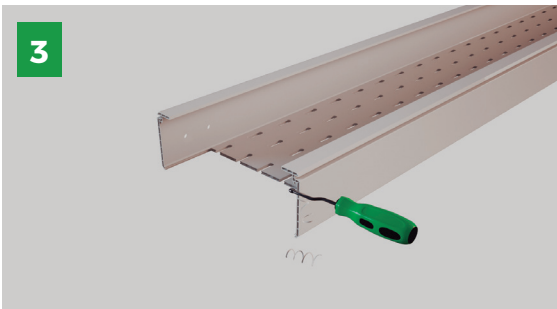
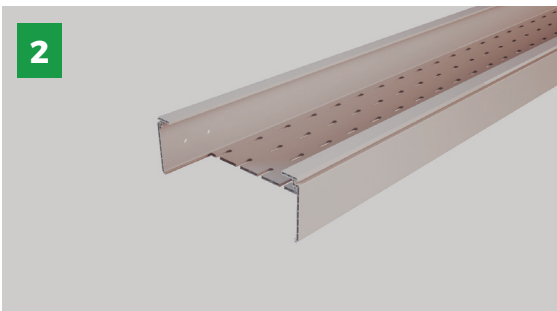
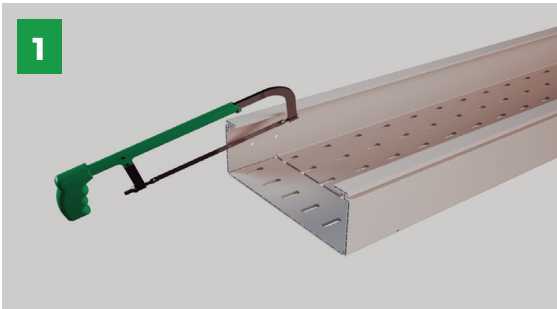

INSTRUCTIONS / INSTRUCCIONES

EN

1. Cut the tray piece removing the base with the cutting saw.
2. Separate the pieces.
3. Remove any rough edges with the de-burring machine.
4. Make 4 holes on the piece with the electric drill.
5. Put 2 union joints JUBPE-B (2/3520 for the 60mm or 2/5038 for the 100mm) in the correct position and fix the union joints on the tray using 8 screws B2-P (2/10017).

ES

1. Cortar la bandeja quitando la base con una sierra de mano.
2. Separar las dos piezas
3. Quitar las superficies rugosas con una rebabadora .
4. Hacer 4 agujeros en cada pieza con un taladro eléctrico.
5. Poner 2 juntas de unión JUBPE-B (2/3520 para altura 60 o 2/5038 para altura 100) en la posición correcta, fija cada una de ellas a la bandeja con 4 tornillos y 4 tuercas B2-P (2/10017), usando en total 8 tornillos y 8 tuercas.

Outside Bends / Large radius Curvas convexas / Radio largo

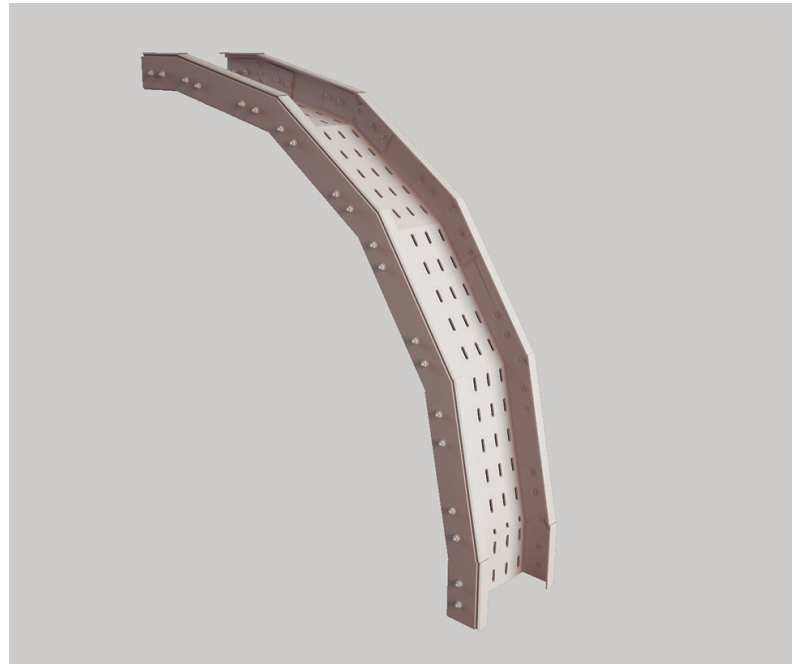
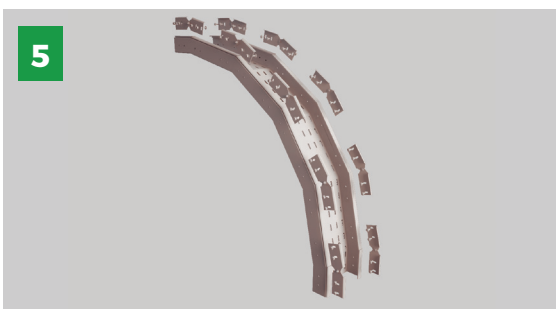
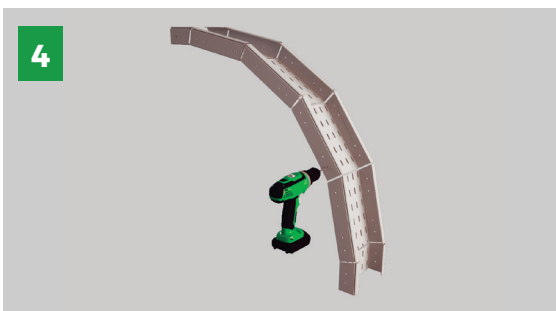
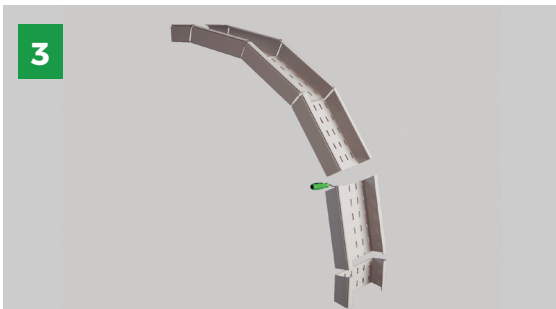
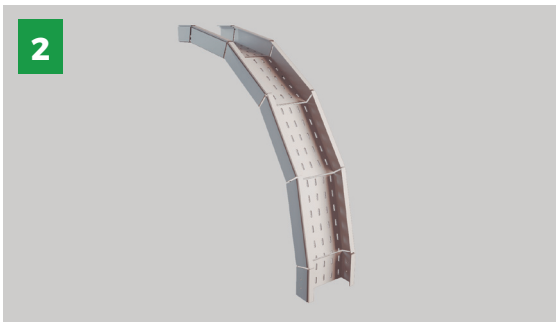
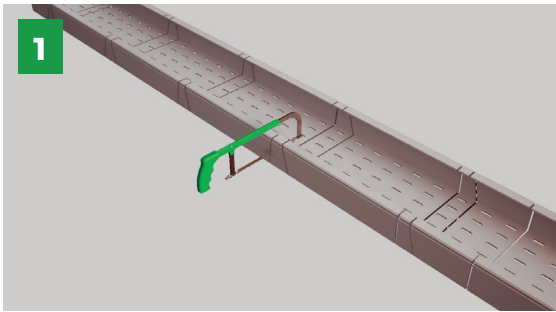

INSTRUCTIONS / INSTRUCCIONES

EN

1. Cut the tray piece with the cutting saw in 6 pieces making a 45° angle cut.
2. Separate the 6 pieces.
3. Remove any rough edges with the de-burring machine.
4. Make 4 holes on each piece with the electric drill.
5. Put 10 union joints JUBPE-A (2/5036 for the 60mm or 2/5037 for the 100mm) in the correct position and fix the union joints on the tray using 40 screws B2-P (2/10017).

ES

1. Cortar la bandeja inclinada en 6 trozos a 45° con una sierra de mano.
2. Separar las 6 piezas.
3. Quitar las superficies rugosas con una rebabadora.
4. Hacer 4 agujeros en cada pieza con un taladro eléctrico.
5. Poner 10 juntas de unión JUBPE-A (2/5036 para altura 60 o 2/5037 para altura 100) en la posición correcta, fija cada una de ellas a la bandeja con 4 tornillos y 4 tuercas B2-P (2/10017), usando en total 40 tornillos y 40 tuercas.

Tee Bends Tés

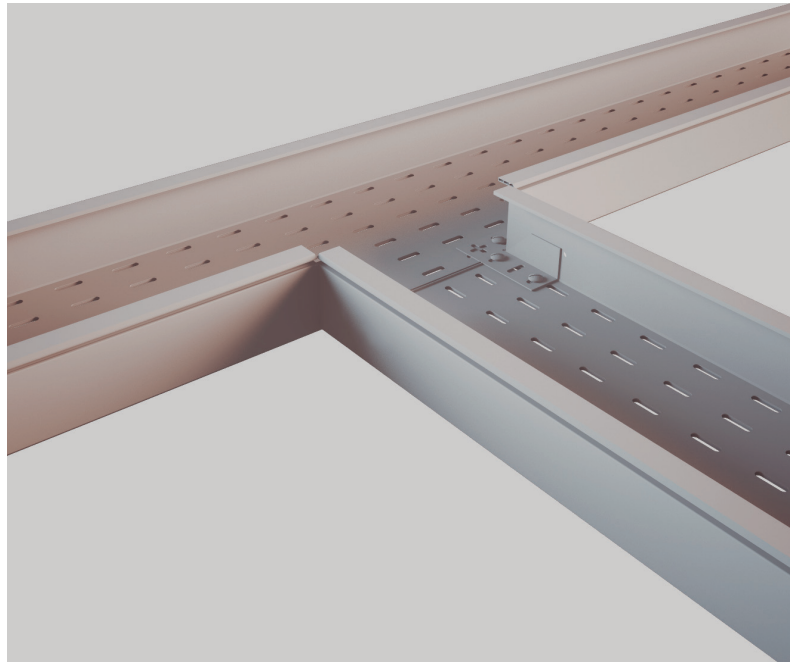
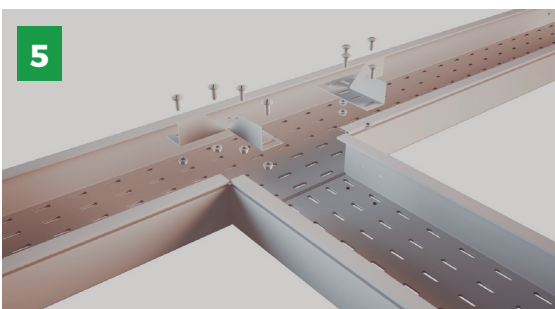
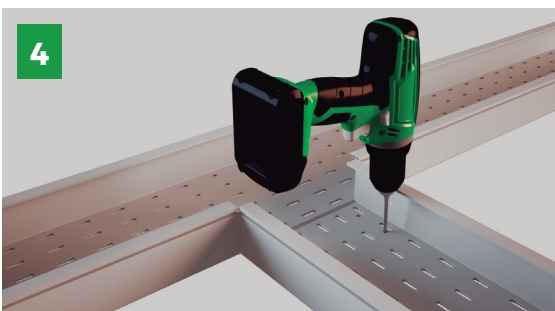
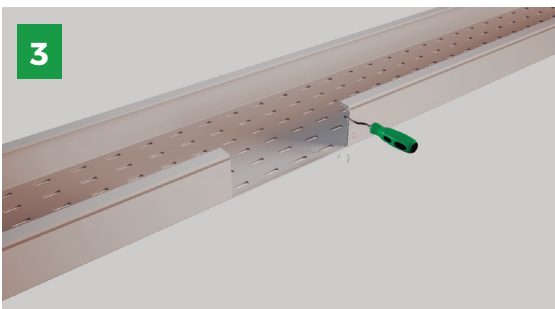
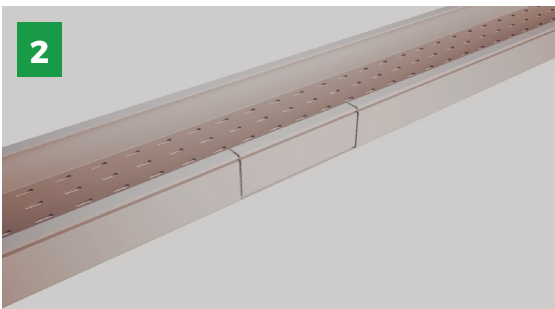
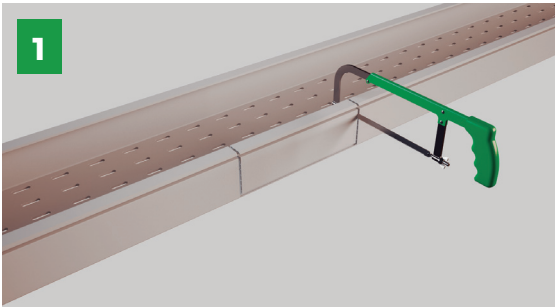

INSTRUCTIONS / INSTRUCCIONES

EN

1. Cut the tray piece removing the side body with the cutting saw.
2. Separate the 2 pieces.
3. Remove any rough edges with the de-burring machine.
4. Make 4 holes on the piece with the electric drill.
5. Put 2 derivation pieces PDBPE (2/10127) in the correct position and fix it on the tray using 8 screws B2-P (2/10017).

ES

1. Cortar la bandeja quitando un ala con una sierra de mano.
2. Separar las 2 piezas.
3. Quitar las superficies rugosas con una rebabadora
4. Hacer 4 agujeros en cada pieza con un taladro eléctrico.
5. Poner 2 juntas de derivación PDBPE (2/10127) en la posición correcta, fija cada una de ellas a la bandeja con 8 tornillos y 8 tuercas B2-P (2/10017).

Cross Bends Cruces

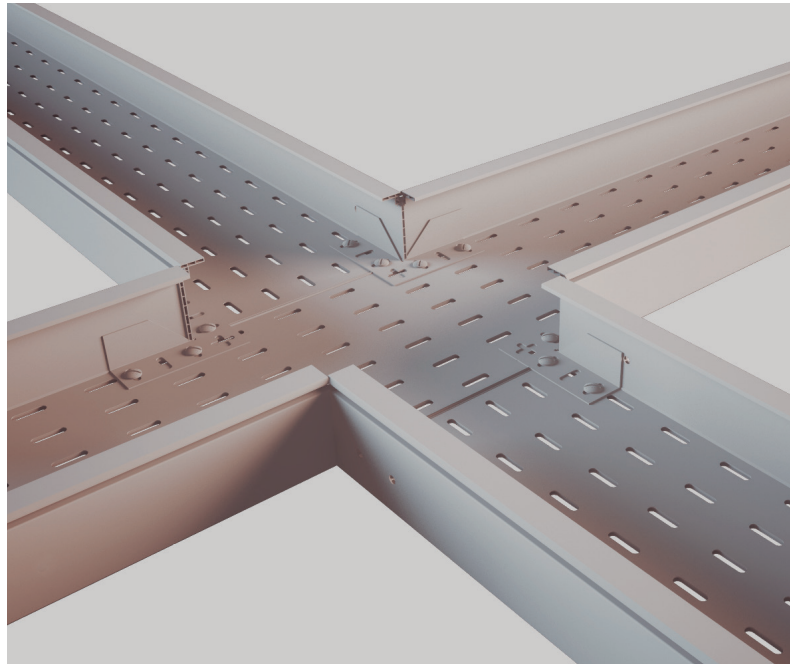
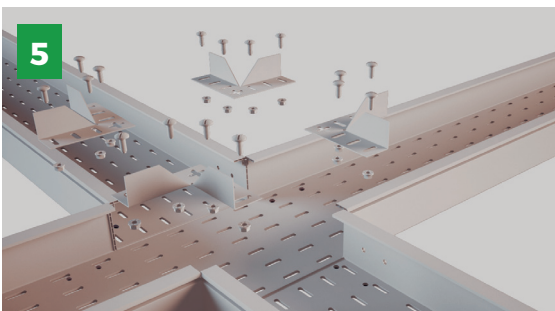
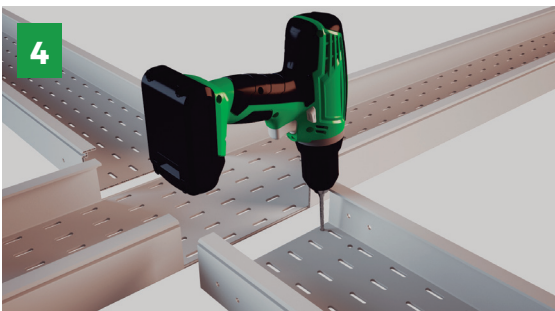
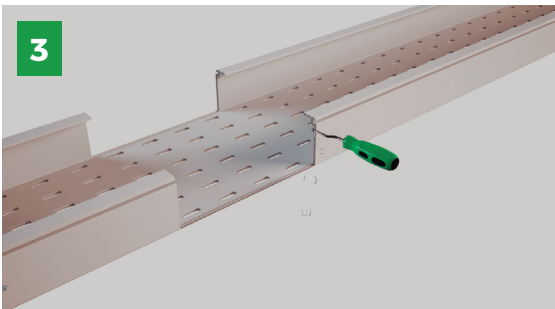
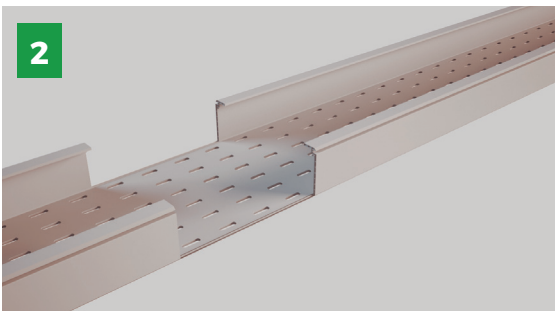
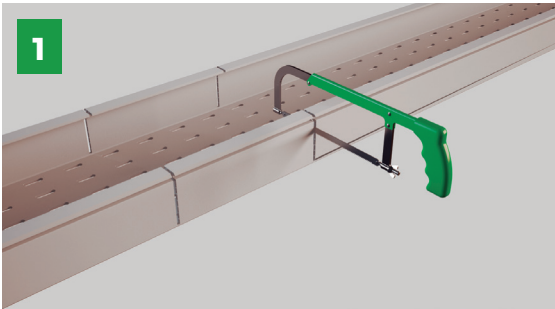

INSTRUCTIONS / INSTRUCCIONES

EN

1. Cut the tray piece removing the 2 side body with the cutting saw.
2. Separate the 2 piece.
3. Remove any rough edges with the de-burring machine.
4. Make 4 holes on the piece with the electric drill.
5. Put 4 derivation pieces PDBPE (2/10127) in the correct position and fix it on the tray using 16 screws B2-P (2/10017).

ES

1. Cortar la bandeja quitando las dos alas con una sierra de mano.
2. Separar las piezas.
3. Quitar las superficies rugosas con una rebabadora .
4. Hacer 4 agujeros en cada pieza con un taladro eléctrico.
5. Poner 4 juntas de derivación PDBPE (2/10127) en la posición correcta, fija cada una de ellas a la bandeja con 16 tornillos y 16 tuercas B2-P (2/10017).

Elevation Changes Cambios de nivel

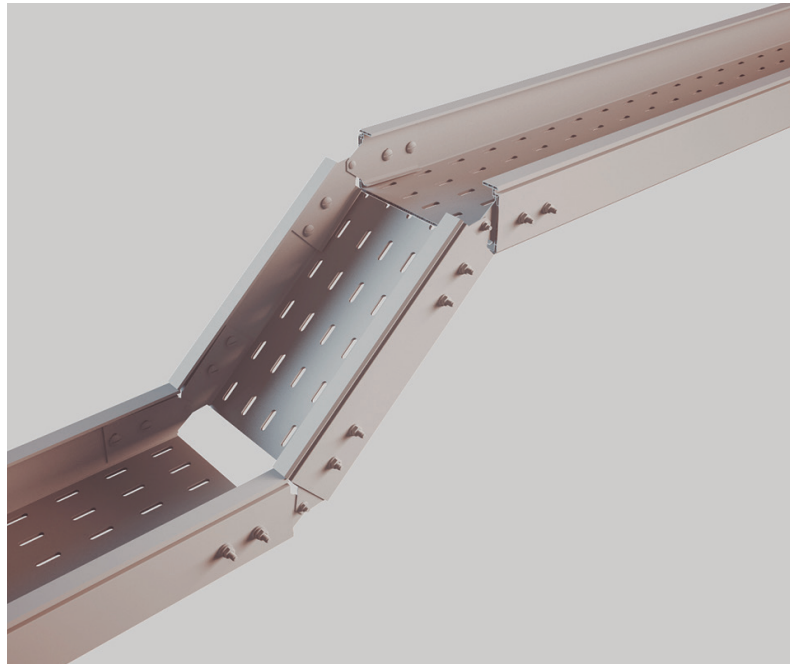
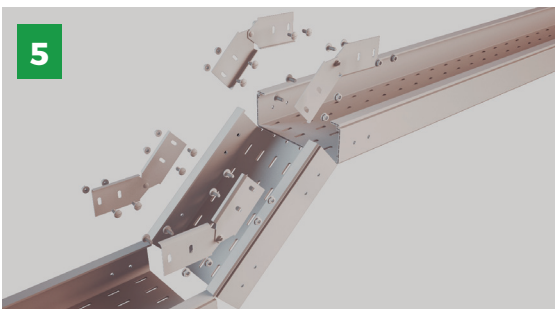
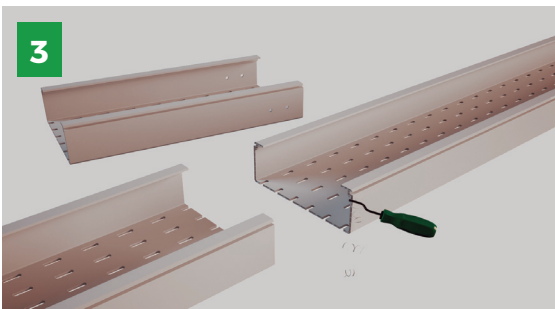
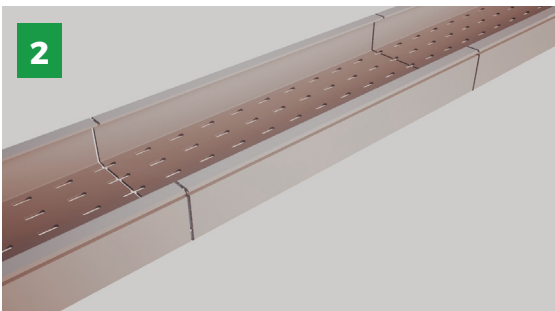
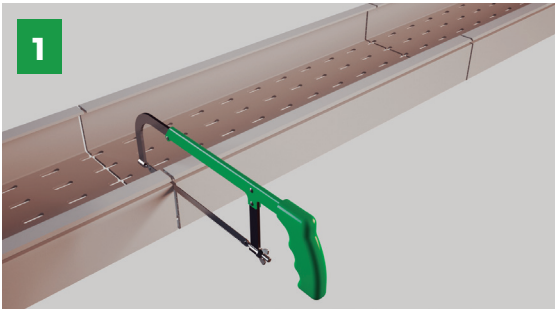

INSTRUCTIONS / INSTRUCCIONES

EN

1. Cut the tray piece with a cutting saw in 3 pieces making a straight cut.
2. Separate the 3 pieces.
3. Remove any rough edges with the de-burring machine.
4. Make 8 holes on each piece with the electric drill.
5. Put 4 union joints JUBPE-A (2/5036 for the 60mm or 2/5037 for the 100mm) in the correct position and fix the union joints on the tray using 16 screws B2-P (2/10017).

ES

1. Cortar en 3 trozos la bandeja con una sierra de mano mediante un corte recto.
2. Separar las 3 piezas.
3. Quitar las superficies rugosas con una rebabadora .
4. Hacer 8 agujeros en cada pieza con un taladro eléctrico.
5. Poner 4 juntas de unión JUBPE-A (2/5036 para altura 60 o 2/5037 para altura 100) en la posición correcta, fija cada una de ellas a la bandeja con 16 tornillos y 16 tuercas B2-P (2/10017).

Application on strut / Solid bottom Aplicación en perfil / Ciega

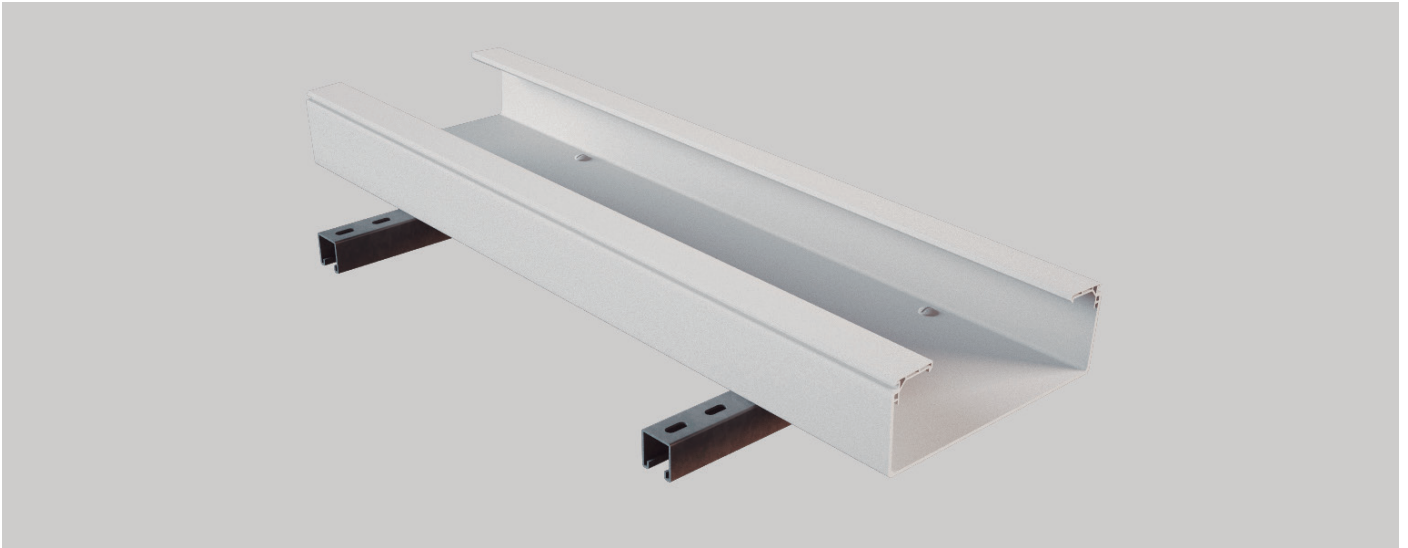

INSTRUCTIONS / INSTRUCCIONES

EN

1. Put the strut on the base of the tray and mark the holes.
2. Make 4 holes on the tray with the electric drill.
3. Fix the strut on the tray using 4 screws B2-P (2/10017).

ES

1. Poner el perfil en la base de la bandeja y marca los huecos.
2. Hacer 4 agujeros en la bandeja con un taladro.
3. Fijar cada una de ellos a la bandeja con 4 tornillos y 4 tuercas B2-P (2/10017).

Application on strut / Slotted Aplicación en perfil / Perforadas

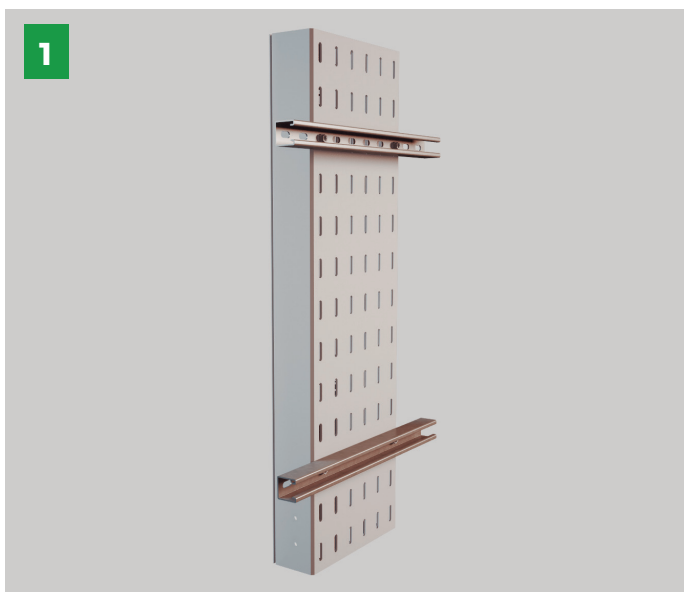
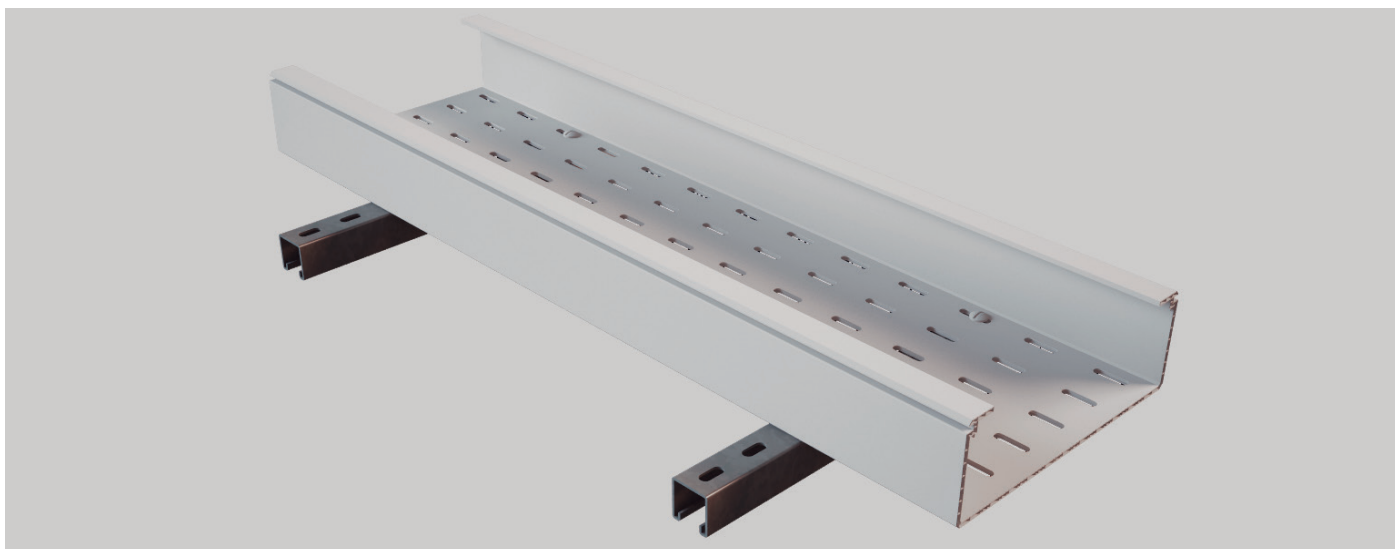

INSTRUCTIONS / INSTRUCCIONES

EN

1. Put the strut on the base of the tray.
2. Fix the strut on the tray using 4 screws B2-P (2/10017).

ES

1. Poner el perfil en la base de la bandeja.
2. Fijar cada una de ellos a la bandeja con 4 tornillos y 4 tuercas B2-P (2/10017).

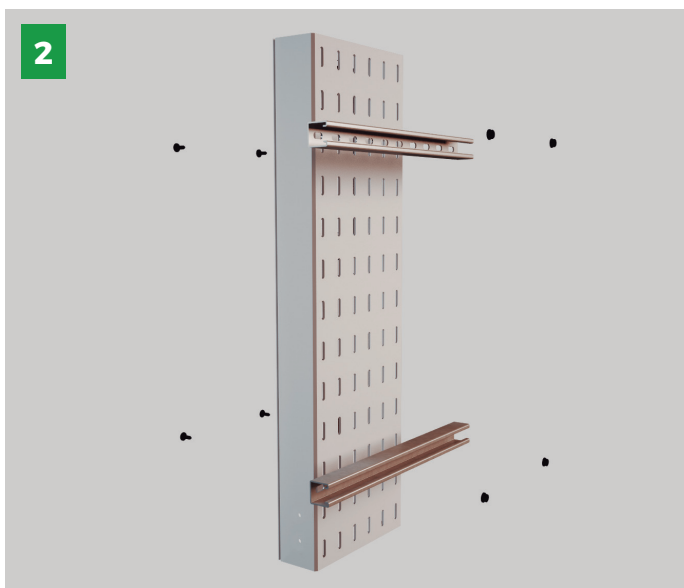



BASORPLAST

3E Basor

CABLE TRAY SPECIALIST



UNE-EN 61537
UNE-EN 50085



UNE-EN 61537
UNE-EN 50085
UNE 23727
UL94



UNE-EN 60695



UNE-EN 61537



UNE-EN 50085

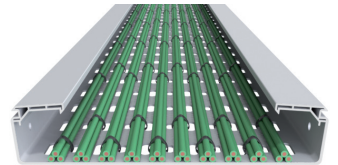
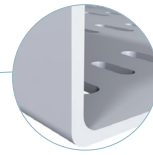
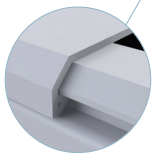

Mod. 60x100 10J
UNE-EN 61537
UNE-EN 50085

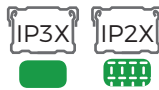

IEC 60529



IEC 50102



ISO/TR 10358
DIN 8061



TBPE

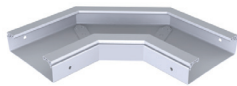

CPBPE



TCPBPE



CCBPE



TCCBPE



CXBPE

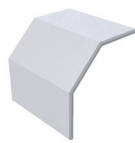

TCXBPE



PDBPE

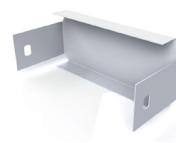

TFBPE



PSBPE



JUBPE

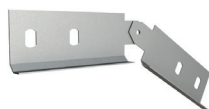

JUBPE-A

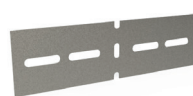

JUBPE-B



CTBP



KABELBAHN BPE-P / H60



3m (10ft)	↑ ↓		↔		PVC M1 UV	KG/M
	mm	inch	mm	inch		
BPE 60X100	60	2 3/8"	100	4"	2/10070	0.73
BPE 60X150	60	2 3/8"	150	6"	2/10071	0.98
BPE 60X200	60	2 3/8"	200	8"	2/10072	1.45
BPE 60X300	60	2 3/8"	300	12"	2/10073	2.34

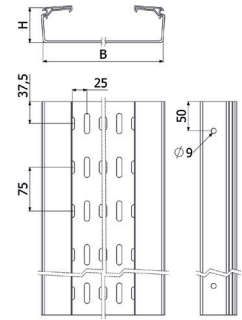

KABELBAHN BPE-C / H60



3m (10ft)	↑ ↓		↔		PVC M1 UV	KG/M
	mm	inch	mm	inch		
BPE-C 60X100	60	2 3/8"	100	4"	2/10062	0.77
BPE-C 60X150	60	2 3/8"	150	6"	2/10063	1.03
BPE-C 60X200	60	2 3/8"	200	8"	2/10064	1.54
BPE-C 60X300	60	2 3/8"	300	12"	2/10065	2.48

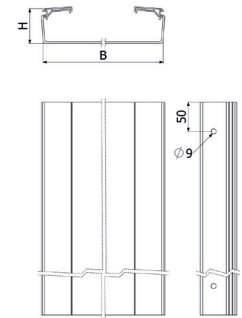

KABELBAHN BPE-P / H100



3m (10ft)	↑ ↓		↔		PVC M1 UV	KG/M
	mm	inch	mm	inch		
BPE 100X200	100	4"	200	8"	2/10074	2.25
BPE 100X300	100	4"	300	12"	2/10075	3.63
BPE 100X400	100	4"	400	16"	2/10076	4.30
BPE 100X600	100	4"	600	24"	2/10077	6.40

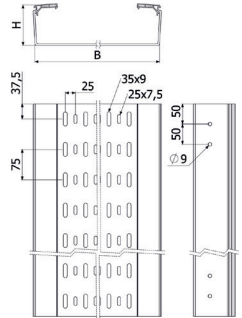

KABELBAHN BPE-C / H100



3m (10ft)	↑ ↓		↔		PVC M1 UV	KG/M
	mm	inch	mm	inch		
BPE-C 100X200	100	4"	200	8"	2/10066	2.38
BPE-C 100X300	100	4"	300	12"	2/10067	3.45
BPE-C 100X400	100	4"	400	16"	2/10068	4.54
BPE-C 100X600	100	4"	600	24"	2/10069	6.72

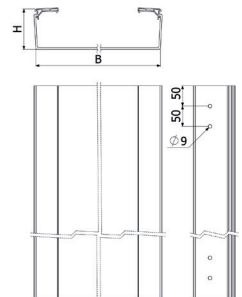

ABDECKUNGEN TBPE



3m (10ft)	↔		PVC M1 UV	KG/M
	mm	inch		
TBPE 100	100	4"	2/10078	0.37
TBPE 150	150	6"	2/10079	0.50
TBPE 200	200	8"	2/10080	0.77
TBPE 300	300	12"	2/10081	1.10
TBPE 400	400	16"	2/10082	1.53
TBPE 600	600	24"	2/10083	2.10

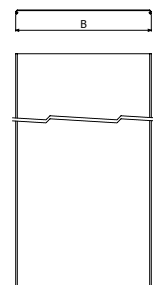

FLACHBOGEN 90° CPBPE



CPBPE	↓↑		↔		📄	
	mm	inch	mm	inch	PVCM1 UV	KG/UD
CPBPE 60X100	60	2 3/8"	100	4"	2/10089	0.40
CPBPE 60X150	60	2 3/8"	150	6"	2/10090	0.54
CPBPE 60X200	60	2 3/8"	200	8"	2/10091	0.91
CPBPE 60X300	60	2 3/8"	300	12"	2/10092	1.61
CPBPE 100X200	100	4"	200	8"	2/10093	1.24
CPBPE 100X300	100	4"	300	12"	2/10094	2.14
CPBPE 100X400	100	4"	400	16"	2/10095	3.27
CPBPE 100X600	100	4"	600	24"	2/10096	4.08

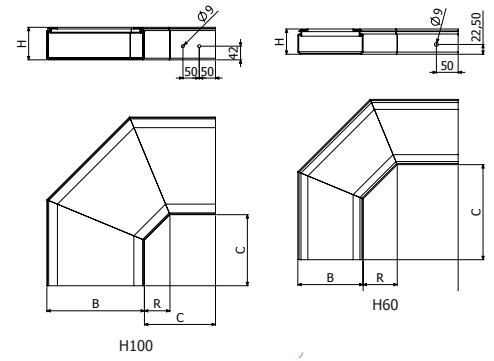

ABDECKUNGEN TCPBPE



TCPBPE	B		C		📄	
	mm	inch	mm	inch	PVCM1 UV	KG/UD
TCPBPE 100	100	4"	220	8 1/2"	2/10097	0.18
TCPBPE 150	150	6"	220	8 1/2"	2/10098	0.26
TCPBPE 200	200	8"	220	8 1/2"	2/10099	0.43
TCPBPE 300	300	12"	220	8 1/2"	2/10100	0.71
TCPBPE 400	400	16"	220	8 1/2"	2/10101	1.12
TCPBPE 600	600	24"	240	9 1/2"	2/10102	1.94

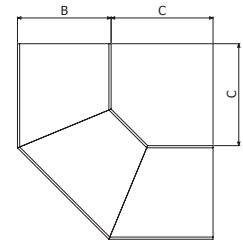

VERTIKALBOGEN STEIGEND CCBPE



CCBPE	↓↑		↔		R		📄	
	mm	inch	mm	inch	mm	inch	PVCM1 UV	KG/UD
CCBPE 60X100	60	2 3/8"	100	4"	240	9 1/2"	2/10103	0.39
CCBPE 60X150	60	2 3/8"	150	6"	240	9 1/2"	2/10104	0.49
CCBPE 60X200	60	2 3/8"	200	8"	240	9 1/2"	2/10105	0.78
CCBPE 60X300	60	2 3/8"	300	12"	240	9 1/2"	2/10106	1.19
CCBPE 100X200	100	4"	200	8"	275	10 3/8"	2/10107	1.37
CCBPE 100X300	100	4"	300	12"	275	10 3/8"	2/10108	1.98
CCBPE 100X400	100	4"	400	16"	275	10 3/8"	2/10109	2.55
CCBPE 100X600	100	4"	600	24"	275	10 3/8"	2/10110	3.23

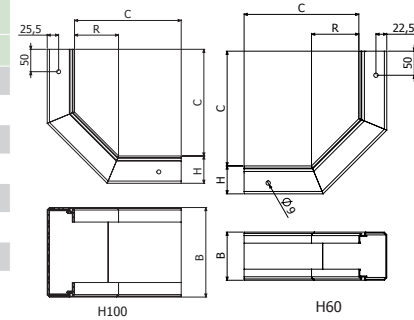

ABDECKUNGEN TCCBPE



TCCBPE	B		📄	
	mm	inch	PVCM1 UV	KG/UD
TCCBPE 60X100	100	4"	2/10111	0.18
TCCBPE 60X150	150	6"	2/10112	0.24
TCCBPE 60X200	200	8"	2/10113	0.37
TCCBPE 60X300	300	12"	2/10114	0.52
TCCBPE 100X200	200	16"	2/10115	0.56
TCCBPE 100X300	300	12"	2/10116	0.61
TCCBPE 100X400	400	16"	2/10117	0.81
TCCBPE 100X600	600	24"	2/10118	1.04

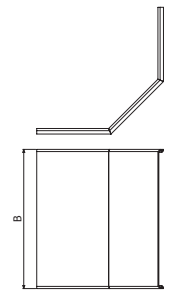

KREUZUNG PDBPE



PDBPE	📄	
	GSP 7035	KG/UD
PDBPE 60/100	2/10135	0.24

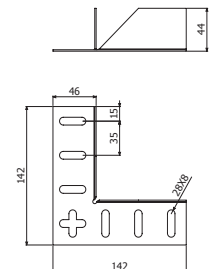

VERTICALBOGEN FALLEND CXBPE



CXBPE	↑		←		R		PVC M1 UV	KG/UD
	mm	inch	mm	inch	mm	inch		
CXBPE 60X100	60	2 3/8"	100	4"	100	4"	2/10119	0.39
CXBPE 60X150	60	2 3/8"	150	6"	100	4"	2/10120	0.49
CXBPE 60X200	60	2 3/8"	200	8"	100	4"	2/10121	0.78
CXBPE 60X300	60	2 3/8"	300	12"	100	4"	2/10122	1.19
CXBPE 100X200	100	4"	200	8"	115	4 5/8"	2/10123	1.37
CXBPE 100X300	100	4"	300	12"	115	4 5/8"	2/10124	1.98
CXBPE 100X400	100	4"	400	16"	115	4 5/8"	2/10125	2.55
CXBPE 100X600	100	4"	600	24"	115	4 5/8"	2/10126	3.23

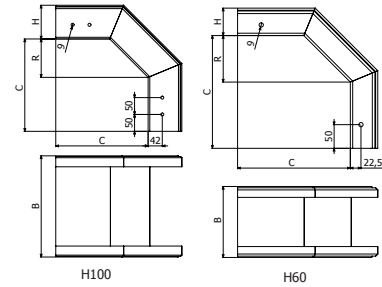

ABDECKUNGEN TCXBPE



TCXBPE	B		PVC M1 UV	KG/UD
	mm	inch		
TCXBPE 60X100	100	4"	2/10127	0.22
TCXBPE 60X150	150	6"	2/10128	0.30
TCXBPE 60X200	200	8"	2/10129	0.49
TCXBPE 60X300	300	12"	2/10130	0.65
TCXBPE 100X200	200	16"	2/10131	0.75
TCXBPE 100X300	300	12"	2/10132	0.82
TCXBPE 100X400	400	16"	2/10133	1.14
TCXBPE 100X600	600	24"	2/10134	1.39

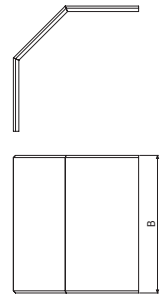

ENDDECKEL CCBPE

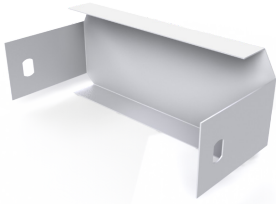

TFBPE	↑		←		GSP 7035	KG/UD
	mm	inch	mm	inch		
TFBPE 60X100	60	2 3/8"	100	4"	2/10136	0.09
TFBPE 60X150	60	2 3/8"	150	6"	2/10137	0.13
TFBPE 60X200	60	2 3/8"	200	8"	2/10138	0.15
TFBPE 60X300	60	2 3/8"	300	12"	2/10139	0.21
TFBPE 100X200	100	4"	200	8"	2/10140	0.24
TFBPE 100X300	100	4"	300	12"	2/10141	0.31
TFBPE 100X400	100	4"	400	16"	2/10142	0.40
TFBPE 100X600	100	4"	600	24"	2/10143	0.55

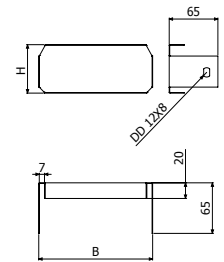

TRENNSTEG PSBPE



PSBPE	3M		H		PVC M1 UV	KG/M
	mm	inch	mm	inch		
PSBPE 60	60	2 3/8"	2/10144	0.09		
TPSBPE 100	100	4"	2/10145	0.13		

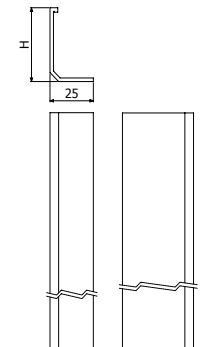

VERTIKALES GELENKSTÜCK JUBPE-A

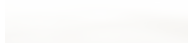
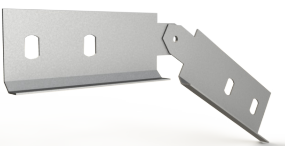

JUBPE-A	↑		i304	KG/UD
	mm	inch		
JUBPE-A 60	60	2 3/8"	2/5036	0.09
JUBPE-A 100	100	4"	2/5037	0.16

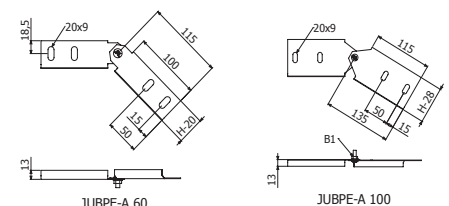

HORIZONTALES GELENKSTÜCK JUBPE



JUBPE	Dimensions		Material & Weight	
	mm	inch	PVCM1 UV	KG/UD
JUBPE 60	60	2 3/8"	2/10084	0.05
JUBPE 100	100	4"	2/10085	0.09

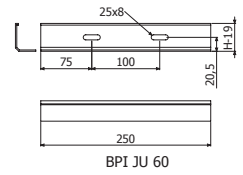

BPI JU 60

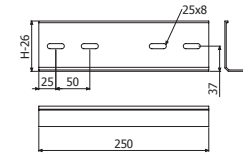

BPI JU 100



SCHRAUBE TCPBPE



CTBP	Material & Weight	
	PVCM1 UV	KG/UD
CTBP-100	2/10017	0.40

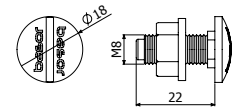

GELENKSTÜCK JUBPE-B

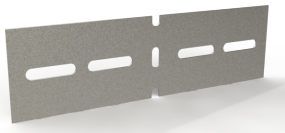

JUBPE-B	Dimensions		Material & Weight	
	mm	inch	i304	KG/UD
JUBPE-B 60	60	2 3/8"	2/3520	0.13
JUBPE-B 100	100	4"	2/5038	0.22

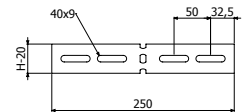

JUBPE-B 60

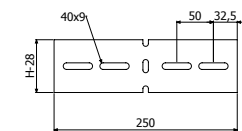

JUBPE-B 100



BIK10-BPE



BIK10-BPE	e mm	Mod HxB	Material & Weight			
			i304	KG/UD	i316	KG/UD
BIK10-BPE 60X100	1.5	60x100	2/17340	0.03	2/17347	0.03
BIK10-BPE 60X150	1.5	60x150	2/17341	0.05	2/17348	0.05
BIK10-BPE 60/100X200	1.5	60/100x200	2/17342	0.07	2/17349	0.07
BIK10-BPE 60/100X300	1.5	60/100x300	2/17343	0.09	2/17350	0.09
BIK10-BPE 100X400	2	100x400	2/17345	0.20	2/17352	0.20
BIK10-BPE 100X600	2	100x600	2/17346	0.49	2/17353	0.49

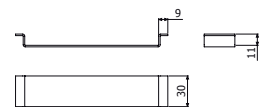

KSHGR



KSHGR	Material & Weight	
	GSP 7035	KG/UD
KSHGR	2/17282	0.61

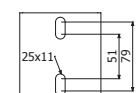
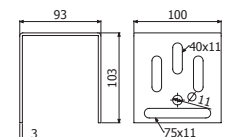

U-PROFIL PSHG-PSHGR



PSHG-PSHGR		
	PVCM1 UV	KG/UD
PSHG 2M	2/17281	2.29
PSHGR 600	2/17283	2.05
TFSHGR PVC	2/12112	0.25

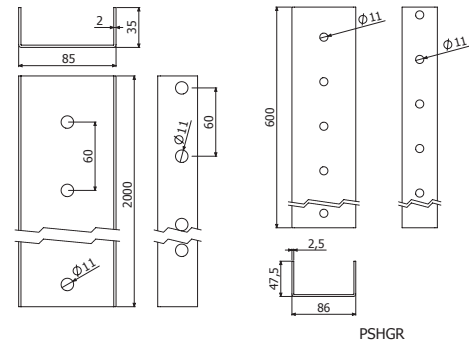

PSHGR

SCHRAUBEN CT2



CT2		
	PVCM1 UV	KG/UD
CT2 M10X100	2/17228	0.11

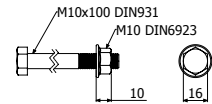

KONSOLE SHG

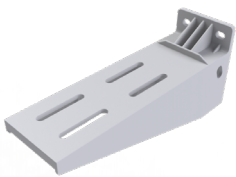

SHG	↔			
	mm	inch	PVM1UV	KG/UD
SHG 100	100	4"	2/10011	0.19
SHG 150	150	6"	2/10012	0.27
SHG 200	200	8"	2/10013	0.34
SHG 300	300	12"	2/10014	0.54
SHG 400	400	16"	2/10015	0.95
SHG 600	600	24"	2/10016	1.10

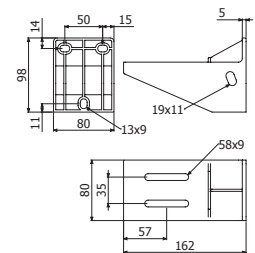

SHG100

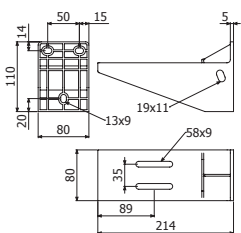

SHG150

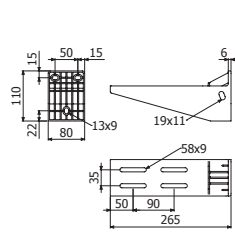

SHG200

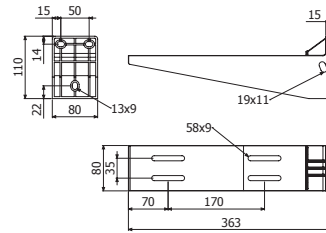

SHG300

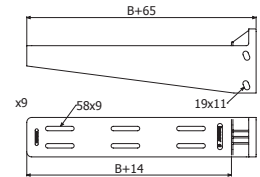

SHG 400/600

KONSOLE SVG

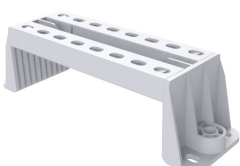

SVG	↔			
	mm	inch	PVM1UV	KG/UD
SVG 100	100	4"	2/10050	0.23
SVG 150	150	6"	2/10051	0.26
SVG 200	200	8"	2/10052	0.28
SVG 300	300	12"	2/10053	0.33
SVG 400	400	16"	2/10054	0.38
SVG 600	600	24"	2/10055	0.48

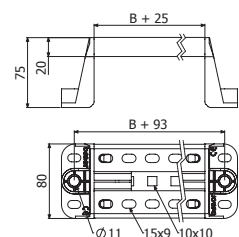

Application on brackets Aplicación en soporte

Floor
Support SVG

Suelo
Soporte SVG

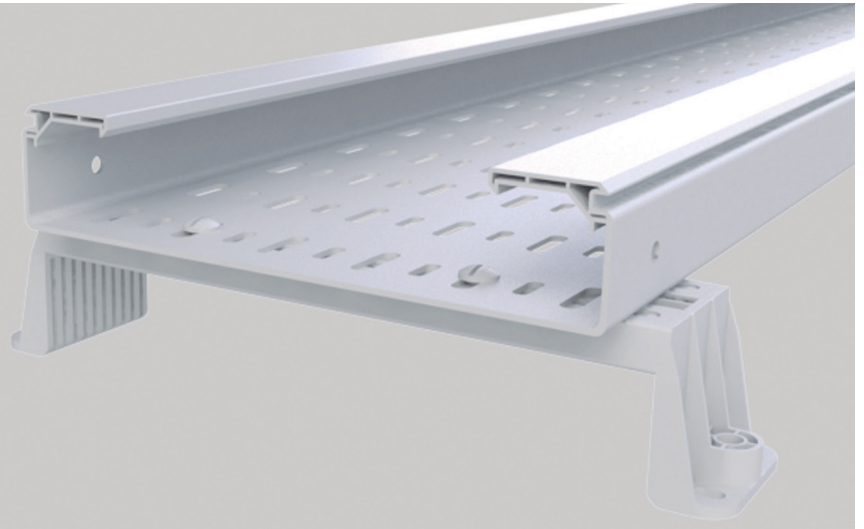

Wall
Support SHG

Pared
Soporte SHG



Ceiling
Support SVG

Techo
Soporte SVG

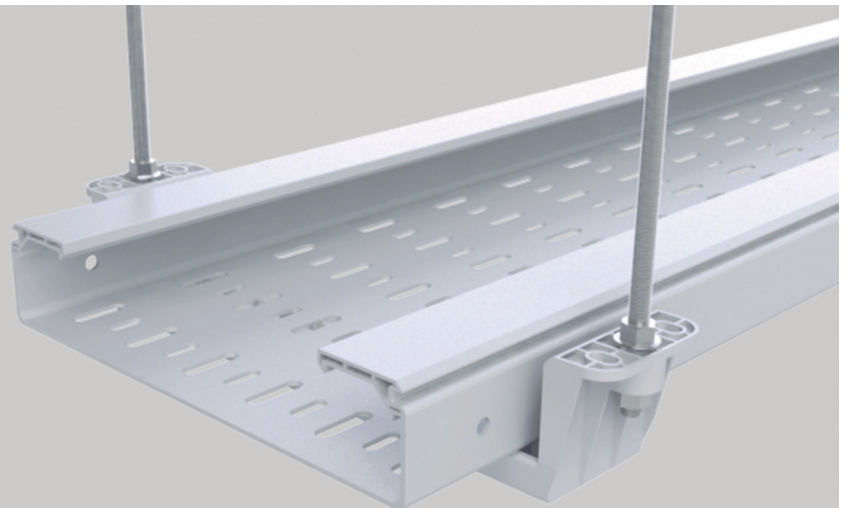

PRESENCIA A NIVEL MUNDIAL

- 10 Filiales internacionales
- 50 Países con stock de productos
- 1.200 Distribuidores globales

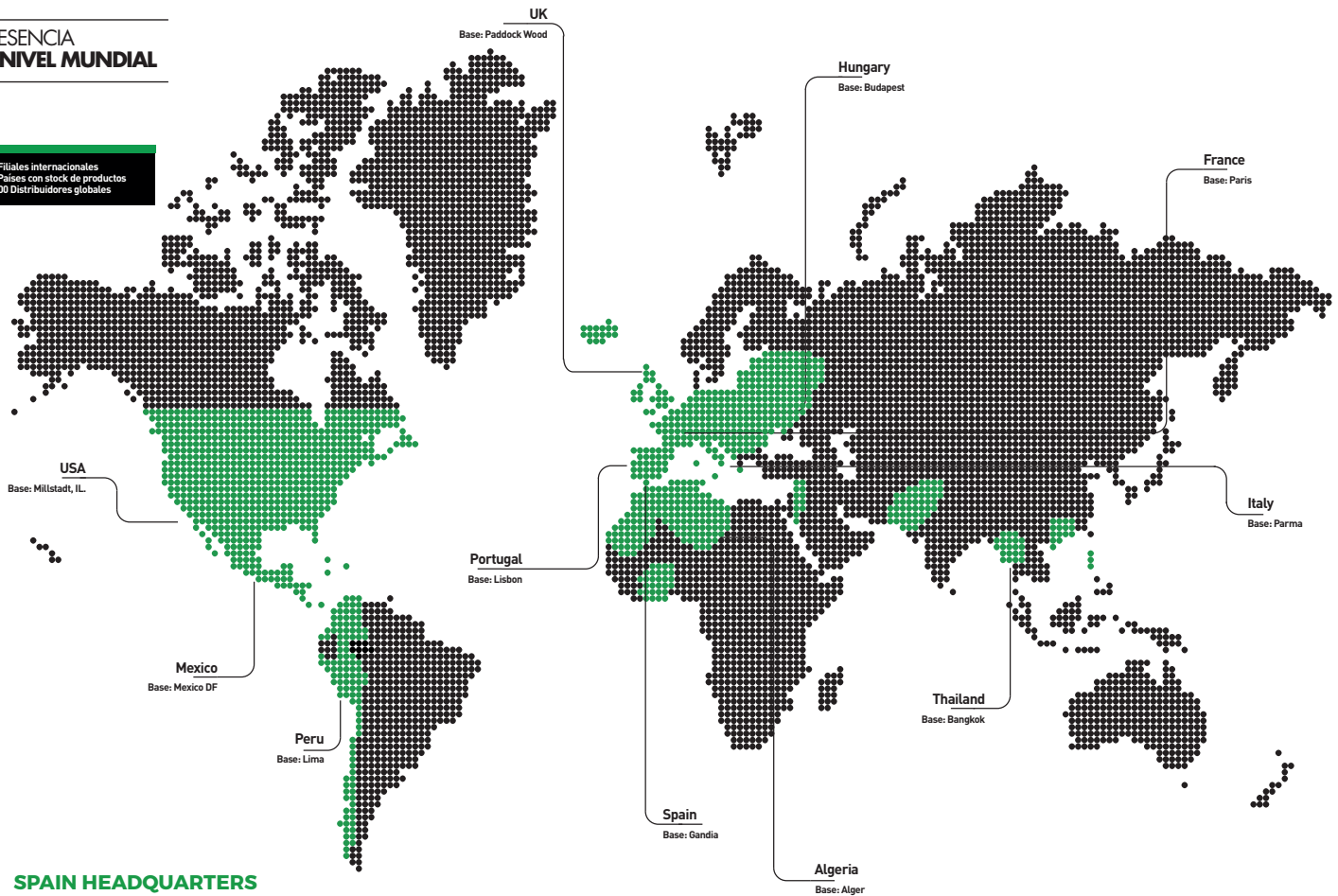

SPAIN HEADQUARTERS

Avenida Alcodar 45-47
46701 Gandia SPAIN
T. +34.962.876.695

ITALY Basor Electric SRL

Via B. Franklin, 31
43122 Parma
T. +39.0521.798.360

HUNGARY Basor Elektro KFT

Grassalkovic U.255
H-1239 Budapest
T. +361.297.0204

ARGELIA Basor SARL M.N.A Equipments

28, Avenue Colonel Bougara
Velle-vue, El-Harrach
T. +213.2152.6234

PORTUGAL Basor Caminho de Cabos

Parque Empresarial Quimiparque
Edif. 153, rua nº42, 21
2830 Barreiro (Lisboa)
T. +351.212.071.165

PERU Basor Perú S.A.C

Av. Alameda Los Horizontes Mz L1
Urb. Huertos de Vila
15054 Chorrillos (Lima)
T. +51.1.759.8367

MEXICO Basor México SAPI

Carretera México-Cuautitlán km31.5 - bodega 33
54800, Cuautitlán, Edo. México, MX
T. +52.55.5546.9092

FRANCE Basor France

27 Rue Edouard Lang
76600 Le Havre
T. +33.02.3541.5409

UNITED KINGDOM Basor Electric LTD

Unit 23, Eldon Way Industrial Estate
Paddock Wod, TN12 6BE, Kent
T. +44.1892.833.500

USA Basor Electric Inc.

609 South Breese • Suite 100
Milstadt, IL 62260
T. +844.393.3985

THAILAND Basor THAI

166/26 soi Charoenporn Charansanitwong rd.,
Baan Changlor
Bangkoknoi, Bangkok 10500
T. +66 0 2 9152300

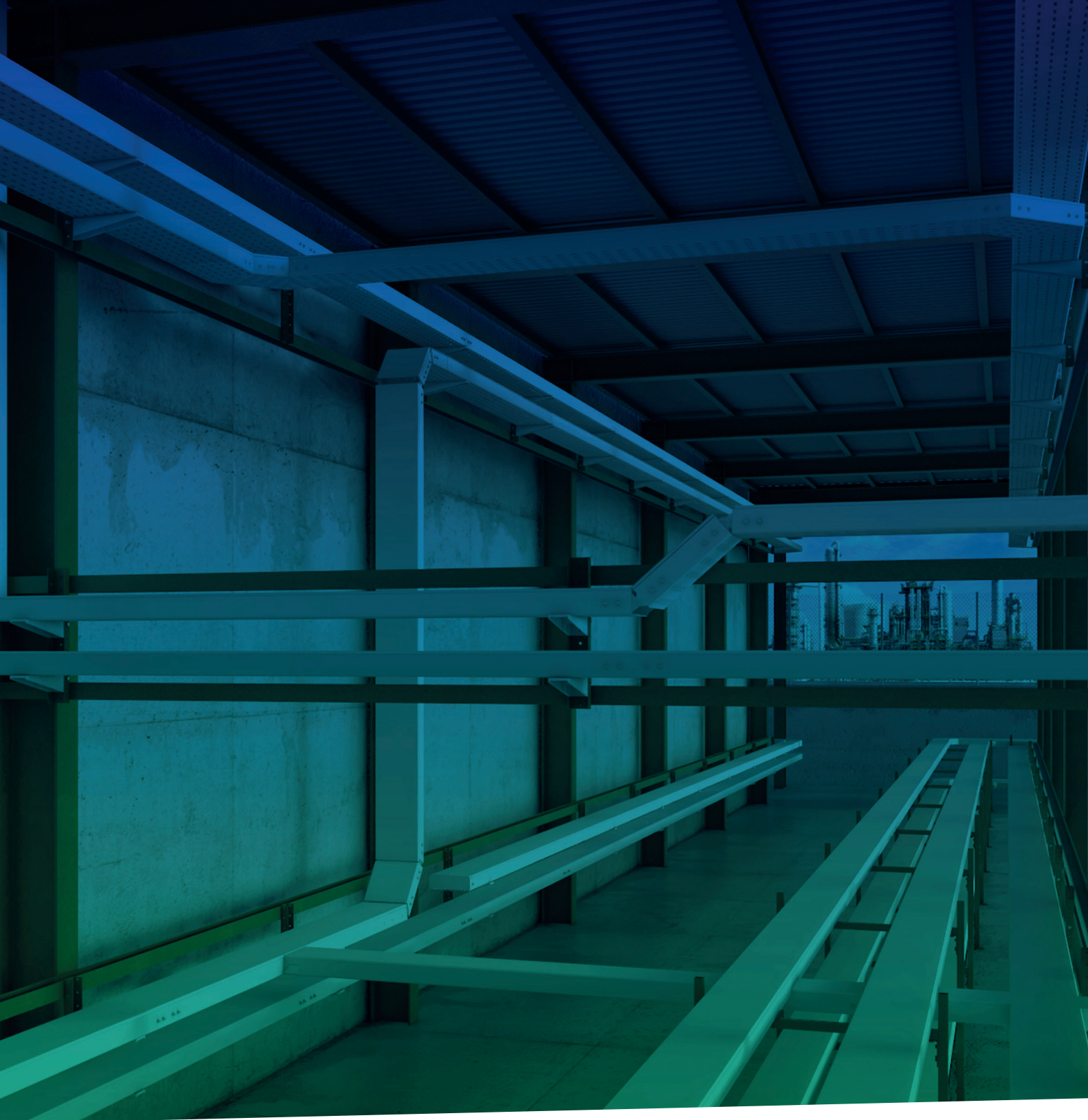

BE Basor

CABLE TRAY SPECIALIST



Basor Electric SA



@Basorelectric



/Basorelectric



www.basor.com