

BE Basor
CABLE TRAY SPECIALIST



TECHNICAL GUIDE GT02



BE Basor
CABLE TRAY SPECIALIST

In the design of an electrical installation with all its cable management lines different aspects such as corrosion, mechanical resistance of the assembly, fire safety, electromagnetic disturbances or price must be considered.

BASOR ELECTRIC has prepared this Technical Technical Guide to facilitate the process of selection and design, and offer maximum information possible on all these aspects, thus maintaining the line of work that has turned BASOR into a Leading business in its field.

INDEX







SECTION 0	Main Selection Criteria	pg. 3
SECTION 1	Cable Management Systems	pg. 5
SECTION 2	Fire Safety	pg. 6
SECTION 3	Mechanical Resistance	pg. 12
SECTION 4	Electrical Continuity	pg. 18
SECTION 5	Electromagnetic Compatibility	pg. 20
SECTION 6	Service temperature: Thermal contractions and expansions	pg. 24
SECTION 7	Ventilation and Degree of sealing	pg. 25
SECTION 8	Corrosion, Materials and Coatings	pg. 26

SECTION 0 MAIN SELECTION CRITERIA MAIN CRITERIA FOR THE SELECTION OF CABLE MANAGEMENT SYSTEMS

For the design and selection of cable management system, depending on the specifications of the project or the conditions to be met at the installation site, there are initially different aspects that may condition our choice.

- 1 Types of Cable Management Systems: Trays, Ladders, Trunkings; Tubes.
- 2 Fire resistance and Fire Propagation: Combustibility, Integrity in Fire.
- 3 Mechanical Resistance: Working Load, Distance between supports, Impact strenght.
- 4 Electrical continuity: Insulation, Conductor, Equipotential bonding.
- 5 Electromagnetic Compatibility (EMC): Data cabling, Disturbances.
- 6 Temperature Conditions: Working conditions in high or low temperatures.
- 7 Cable Ventilation: Types of cabling, Natural ventilation.
- 8 Protection Against Corrosion: Materials and Service Life, Type of Environments, Chemical Products...

The following sections of this technical guide describe these selection criteria.

		CABLE MANAGEMENT SYSTEMS					
		CABLE TRAYS Sheet Steel	CABLE TRAYS Steel Wire	CABLE LADDERS Steel or Aluminium	CABLE CHANNELS Steel or Aluminium	CABLE TRAYS PVC	CABLE LADDERS Fiberglass
							
CHARACTERISTICS	FIRE RESISTANCE	NON-COMBUSTIBLE	NON-COMBUSTIBLE	NON-COMBUSTIBLE	NON-COMBUSTIBLE	NON-FLAMMABLE Does not spread the fire	NON-FLAMMABLE Does not spread the fire
	MECHANICAL RESISTANCE	LOW-MEDIUM HIGH LOAD	LOW-MEDIUM LOAD	VERY HIGH LOADS	LOW-MEDIUM HIGH LOAD	LOW-MEDIUM LOAD	HIGH LOADS
	ELECTRICAL CONTINUITY	EQUIPOTENTIAL BONDING CONDUCTOR	EQUIPOTENTIAL BONDING CONDUCTOR	EQUIPOTENTIAL BONDING CONDUCTOR	EQUIPOTENTIAL BONDING CONDUCTOR	INSULATING DIELECTRIC	INSULATING DIELECTRIC
	ELECTROMAGNETIC DISTURBANCE (EMC)	HIGH PROTECTION	PROTECTION ACCORDING TO ASSEMBLY	MODERATE PROTECTION	TOTAL SHIELDING	WITHOUT PROTECTION	WITHOUT PROTECTION
	TEMPERATURE CONDITIONS	-50°C up to 150°C	-50°C up to 150°C	-50°C up to 150°C	-45°C up to 120°C	-20°C up to 60°C	-50°C up to 150°C
	CABLE VENTILATION	MEDIUM HEAT DISSIPATION	EXCELLENT HEAT DISSIPATION	EXCELLENT HEAT DISSIPATION	WITHOUT VENTILATION	MEDIUM HEAT DISSIPATION	EXCELLENT HEAT DISSIPATION
	PROTECTION AGAINST CORROSION	SELECT ACCORDING TO MATERIALS AND COATINGS (TABLE 2)					EXCELLENT PERFORMANCE

SELECTION ACCORDING TO ENVIRONMENTAL CONDITIONS

Cable Management Systems are adapted to the environmental requirements by means of different solutions, with materials and finishes adapted to each type of environment.



Based on the experience and knowledge acquired internationally about corrosion, the ISO 9223 standard "Corrosivity of atmospheres" defines, based on humidity and the presence of pollutants, different classes of environments C1 to C5 according to the degree of corrosivity towards metals. The same classification is used in ISO 9224 and ISO 14713-1 "Zinc coatings. Protection against corrosion" (see Section 8).

Based on these regulations and user experience, the following table shows the recommendations for the selection of Cable Management Systems.

ENVIRONMENT – Classification according to ISO 9223		AVAILABLE FINISHINGS												
		EZ	GS	EZ1000	GSP	GC	GC70	ZAM3K	GC85	AL	i304	i316	PVC M1	PRFV
Indoor areas in buildings with clean atmospheres, without humidity variations.	C1	RECOMMENDED	RECOMMENDED	EXCESSIVE QUALITY	EXCESSIVE QUALITY	EXCESSIVE QUALITY	EXCESSIVE QUALITY	EXCESSIVE QUALITY	EXCESSIVE QUALITY	EXCESSIVE QUALITY	EXCESSIVE QUALITY	EXCESSIVE QUALITY	EXCESSIVE QUALITY	EXCESSIVE QUALITY
Indoors with low humidity and contamination. Outdoors with a low level of contamination: rural areas.	C2	RECOMMENDED	RECOMMENDED	RECOMMENDED	RECOMMENDED	RECOMMENDED	RECOMMENDED	RECOMMENDED	EXCESSIVE QUALITY	EXCESSIVE QUALITY	EXCESSIVE QUALITY	EXCESSIVE QUALITY	EXCESSIVE QUALITY	EXCESSIVE QUALITY
Indoors with humidity or moderate contamination. Urban and industrial outdoor environments, moderate contamination; coastal areas with low salinity.	C3	POSSIBLE	POSSIBLE	RECOMMENDED	RECOMMENDED	RECOMMENDED	RECOMMENDED	RECOMMENDED	EXCESSIVE QUALITY	EXCESSIVE QUALITY	EXCESSIVE QUALITY	EXCESSIVE QUALITY	EXCESSIVE QUALITY	EXCESSIVE QUALITY
Indoors with high contamination. Outdoor industrial areas with high contamination and coastal areas with moderate salinity.	C4			POSSIBLE	POSSIBLE	POSSIBLE	RECOMMENDED	RECOMMENDED	RECOMMENDED	RECOMMENDED	RECOMMENDED	RECOMMENDED	RECOMMENDED	RECOMMENDED
Indoor spaces with a high frequency of condensation. Industrial areas with very high contamination.	C5-I						POSSIBLE	POSSIBLE	POSSIBLE	RECOMMENDED	RECOMMENDED	RECOMMENDED	RECOMMENDED	RECOMMENDED
Coastal areas with high salinity. Spaces with almost permanent condensation and presence of chlorides.	C5-M							POSSIBLE	POSSIBLE	POSSIBLE	POSSIBLE	RECOMMENDED	RECOMMENDED	RECOMMENDED

■ RECOMMENDED
 ■ POSSIBLE
 EXCESSIVE QUALITY

Main materials and finishings are:

- GS Pre-galvanized steel before manufacturing, continuous process (Sendzimir method).
- GC Hot-dip galvanized steel after manufacturing.
- PVC M1 PVC Thermoplastic Polymer.
- GSP Steel coated with polyester resin, with >1000h Salt Spray resistance.
- EZ1000 Enhanced electro-zinc coating, with high-layer passivation and sealing, >1000h Salt Spray resistance.
- AL Aluminium (Alloys 1050, 5754, 6063, etc.)
- PRFV Glass-fibre reinforced polyester (GRP/FRP).
- ZAM3K Continuously pre-galvanized steel with Zn-Al-Mg alloy coating, high resistance, >3000h Salt Spray resistance.
- i304 AISI 304 Stainless Steel.
- i316 AISI 316 Stainless Steel.
- EZ Electro-zinc steel.

WITH RESISTANCE IN SALT SPRAY TEST > 1000H

SECTION 1 TYPES OF CABLE MANAGEMENT SYSTEMS

The function of supporting the electrical wiring safely along a route is carried out by the cable management systems, which are the structural elements of the electrical installation, in compliance with the UNE-EN IEC 61537 standard.

CABLE TRAYS

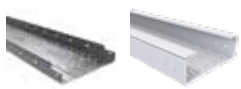

METAL OR PLASTIC

- Used in industrial installations, indoor or outdoor environments
- Load capacity: low, medium and high
- Cable types: communication and power distribution
- Medium cable ventilation

ADVANTAGES OF METAL TRAYS

- Good behavior against external electromagnetic disturbances
- Ease of cable bridging
- Excellent fire behavior, with maintenance of functions in case of fire

ADVANTAGES OF INSULATING CABLE TRAYS

- Electrical safety without the need for earthing
- Ease of wiring bridging
- Excellent corrosion resistance, especially against chemicals and saline environments

CABLE TRAYS



STEEL WIRE

- Used in industrial or tertiary facilities, indoors or outdoors
- Load capacity: low to medium
- Types of cables: communication and power distribution

ADVANTAGES OF STEEL WIRE MESH CABLE TRAYS

- Excellent ventilation and cable visibility
- Quick and easy to install (accessories on site)
- Recommended for dusty / biological environments for ease of cleaning

CABLE LADDERS



STEEL, ALUMINUM, GRP

- Used in industrial installations, indoor or outdoor environments
- Load capacity: high to extremely high
- Cable types: high power

ADVANTAGES OF CABLE LADDERS

- High wiring capacity
- Possibility of firm fixing of cables by means of cable clamps
- For all types of installation and activities requiring long spans and high loads
- Excellent ventilation and cable visibility
- Suitable for cables requiring large bending radius

CABLE TRUNKINGS



METAL OR PLASTIC

- Used in industrial installations, indoor or outdoor environments
- Load capacity: medium to high
- Various metal or plastic conduit applications
- Cable Types: machine power or communication, including fiber optics
- Complete system with cover. Maximum protection of cabling against mechanical risk, dust, liquids, or other elements.

ADVANTAGES OF METAL TRUNKING

- Reinforced mechanical protection
- Optimum protection against any external electromagnetic disturbances
- Floor installation possible with anti-slip covering

ADVANTAGES OF INSULATING TRUNKING

- Electrical safety without earthing or bonding
- Excellent corrosion resistance, especially against chemicals
- No amplification of possible internal electromagnetic disturbances

SECTION 2 FIRE SAFETY

2.1 RISK FACTORS

Basor Electric, sensitive to the need to minimize the consequences of a fire, has tested its Cable Management Systems to rigorous resistance and reaction to fire tests to ensure the performance of its products. Fire safety is characterized by the behaviour of materials against the different aspects related to:

The appearance of a fire: The contribution to the start of a fire after an electric arc or cable overload.

The contribution to the fire: Due to the characteristics of the materials, and their possible combustion.

Its propagation: The behavior after the appearance of the flame, and its evolution until extinction.

The safety conditions for people: Due to the emission of smoke and toxic substances.

Resistance during the fire: To guarantee the operation of emergency equipment.



The following table highlights the main fire risk factors:

		CHARACTERISTICS	REGULATIONS	CLASSIFICATIONS
FIRE SAFETY	FIRE IGNITION	Ignition by electric arc	(Not yet considered)	Insulators: No risk
		Ignition by heat	UNE-EN 60695-2-11	No ignition
	FIRE SPREAD	Flame behavior	IEC product standards; Standardized tests UNE-EN 60695-11-2	Non-flame propagating
	CONTRIBUTION TO FIRE	Flame behavior	IEC product standards; UNE 23727; UNE 201010 UL 94; NF_P92_507	Incombustible: M0 Highly flammable: M1 Combustible: M2; M3
	SMOKE EMISSIONS	The quantity, opacity and toxicity of the smoke	UNE-EN 13501-1 UL 568	No smoke emission Low/medium emission
	FIRE RESISTANCE	Maintenance of functions during a fire	DIN 4102; STN 92 0205; CSN 73 0895 (Not yet covered in IEC Standards)	Resistance (minutes) E30; E60; E90

2.2 REACTION TO FIRE

The first significant differentiation, in terms of their contribution to fire, is that between non-combustible materials and combustible materials. In other words, the fundamental difference in terms of fire behaviour is that there are materials that cannot burn and materials that, with greater or lesser speed and in different ways, can undergo combustion.

Within these two types of materials, the only ones capable of maintaining their functions over time in the presence of fire are non-combustible materials. Within the range of combustible materials there is another differentiation marked by flame propagation or non-flame propagation.

A non-flame-spreading combustible material is one which, when ignited, prevents the spread of fire, i.e., it does not continue to burn when the ignition source is removed.

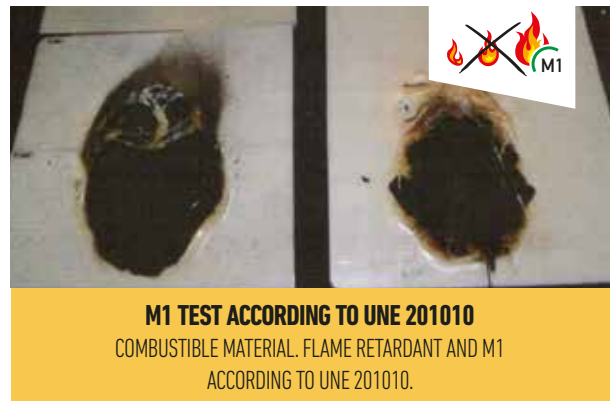

The market has tended to increase more and more the restrictions on non-flame propagating materials, so it has been necessary to use specific standards, of which the best known are the UNE 201010 on reaction to fire of electrical accessories (previously the UNE 23727 on construction materials was used) or the UL94 on flammability of plastic materials.

The main classifications of these standards are as follows:





UNE 201010	M0	Non-combustible material.
	M1	Ignition ≤ 2 seconds, or non-ignited droplets.
	M2	(2 options) -Ignition ≤ 2 seconds with flaming droplets. -Ignition ≤ 5 seconds swelling without swollen droplets.
	M3	
	M4	

UL94	V0	Ignition ≤ 10 seconds, without droplet formation or with non-inflamed droplets.
	V1	Ignition ≤ 30 without droplet formation or with or with non-inflamed droplets.
	V2	Ignitions ≤ 30 seconds, with formation of inflamed droplet formation.
	HB	
	5VB 5VA	



All materials of BASOR cable trays are M0 non-combustible or M1 non-flammable according to the UNE 201010 standard.

Summary of the classification of Cable Management Systems against fire:

		CHARACTERISTICS	CLASSIFICATION	DESCRIPTION	SYMBOL
TYPE OF MATERIAL	INCOMBUSTIBLE	System with function maintenance	E90	Maintains functions 90'	
		Fire resistance according to DIN 4102-12	E60	Maintains functions 60'	
			E30	Maintains functions 30'	
		NO GUARANTEE of function maintenance	M0	Non-combustible material	
	Material classification according to UNE 201010				
	COMBUSTIBLE	Product standard	NO PROPAGATOR OF THE FLAME	Does not continue to burn when ignition source is removed	
		Cable trays UNE-EN 61537, Channels UNE-EN 50085, Pipes UNE-EN 61386			
		Reaction to fire	M1	Classifications according to swelling time, presence of droplets and their characteristics	
		Reaction to fire of electrical accessories according to UNE 201010	M2		
			M3		
			M4		
	Flammability of plastics	V0	Classifications according to swelling time, presence of droplets and their characteristics		
Flammability of plastics according to UL94	V1				
	V2				

Depending on how long it is necessary to maintain the functionality of the installation, we will select the ideal cable management system for each case. The functionality of these installations will be more important in **public places**. In this type of premises more time is needed for its evacuation due to the great accumulation of people.

2.3 FIRE RESISTANCE

In the event of a fire, it is necessary to maintain the functionality of certain electrical installations, such as smoke extractors, emergency lighting, fire alarms, or pressure installations for extinction.



All Basor Electric cable trays are manufactured under the UNE-EN IEC 61537 Standard "Cable tray systems and Cable ladder systems", but in this standard up to this moment the fire resistance of the cable trays has not been developed.

Given this lack of applicable European or international regulations, different local regulations are used, such as the German, Czech and Slovak studies that study the fire behavior of electrical cable systems necessary to maintain the integrity of the circuit.

DIN 4102-12	"Fire behaviour of building materials and elements. Fire resistance of electric cables systems required to maintain circuit integrity"
CSN 730895	"Firesafety engineering - Maintaining the functionality of cable lines under fire conditions - requirements, testing, classification Px-R, R-PHX and applicatio of test results"
STN 920205	"Firebehaviour of construction products and building constructions. Circuit integrity maintenance od cable system. Requirements, testing, classification and aplication of test results"

These standards define the test conditions to verify that the system, made up of fire-resistant trays, supports, accessories and cables, maintains electrical power for a specified time inside an oven in which the fire is simulated following a defined temperature-time curve.

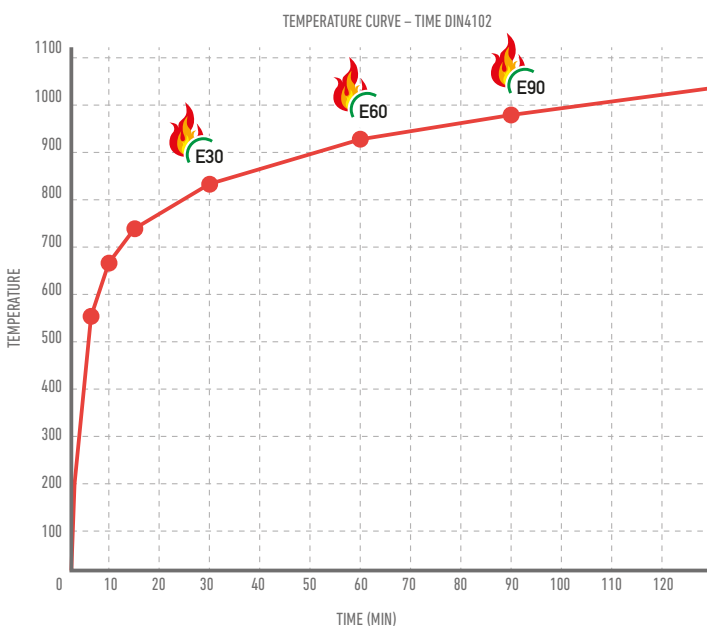

Basor Electric has tested different solutions under these Standards to determine the behaviour and functionality of its products.

These standards study the response of the system formed by the set of fire-resistant cables in service, with the supports and the trays inside a furnace in which the fire is simulated following a defined temperature-time curve.

Over the course of the minutes, the cable trays deform without ceasing to support the cables; and so, although the cable sheathing deteriorates, the system maintains electrical service without short-circuiting or interrupting the signal. The system is classified as E30, E60 or E90 according to the DIN standard, depending on the time, in minutes, that it is able to maintain the installation in service. The selection of the system (E30, E60 or E90) depends on the time required to organise evacuation and emergency services in each case.

*The installations classified as Fire Resistant have been tested in accredited external laboratories, which ensures compliance with all the requirements demanded in the Regulations.

**In addition, selected assemblies have been subsequently evaluated and certified by the corresponding national bodies, thus being certified for use in different countries.

DIN 4102-12		
CLASSIFICATION	TIME OF THE TEST (min)	TEMPERATURE REACHED (°C)
E30	30	822
E60	60	925
E90	90	986

CSN 730895		
CLASSIFICATION	TIME OF THE TEST (min)	TEMPERATURE REACHED (°C)
P15-R	15	738
P30-R	30	822
P45-R	45	902
P60-R	60	925
P90-R	90	986
P120-R	120	1049

STN 920205		
CLASSIFICATION	TIME OF THE TEST (min)	TEMPERATURE REACHED (°C)
PS15	15	738
PS30	30	822
PS45	45	902
PS60	60	925
PS90	90	986
PS120	120	1049



For more information on BASOR ELECTRIC's FIRE-RESISTANT SYSTEMS, please refer to the specific publication.

2.4 THE PLASTIC CABLE TRAYS AND FIRE

The different series of BASOR ELECTRIC cable management systems made of plastic materials comply with the regulatory requirements of the different families of trunkings trays or tubes, with the following specifications:

basorplast



- NON-flame-spread according to UNE-EN IEC 61537; UNE-EN 50085 or UNE-EN IEC 61386.
- Classification of reaction to fire M1, self-extinguishing material (flammability <2sec.), according to UNE 201010, (classification V0 according to UL94).



- They do not contribute to the appearance of fire by preventing the appearance of ignition sources due to short circuits, electric arcs between the live cables and the tray due to defects in the connections, or due to possible overheating caused by overloads or leaks due to insulation failure of the conductors.



- Complies with the glow wire test at 650°C without ignition according to UNE EN 60695-11-2.

- The materials used in the BASORPLAST series, support minimum installation temperatures down to -20°C, and the resistant characteristics are tested under conditions environments up to 60°C.

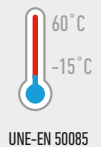

However, combustible materials continue to present a limitation: When the conduction of cables that must remain in service in a fire situation is required, the plastic cable trays are not capable of maintaining the functions for which the installation has been designed for the time required to keep the emergency installations for evacuation of people active in the affected facility.

SECTION 3 MECHANICAL STRENGTH

The main function of Cable Management Systems is to be an efficient and resistant support that facilitates installation. The mechanical characteristics of all products and accessories are tested according to the requirements of the international standards UNE-EN IEC 61537 and NEMA VE.

3.1 SAFE WORKING LOAD (SWL)

The safe working load (SWL) is the maximum load that can be applied in normal use without danger. Therefore, the working load must always be lower than the SWL.

There is no international classification of the cable management system according to its safe working load (SWL). Although countries such as the USA, Canada and Mexico have classifications to define cable management systems by categories according to the SWL.

		DISTANCE BETWEEN SUPPORTS m (ft)						
		1,5 (5)	1,8 (6)	2,4 (8)	3 (10)	3,7 (12)	4,9 (16)	6,1 (20)
SWL kg/m (lb/ft)	18 (12)	5AA	6AA					
	37 (25)	5BB / 5AA	6BB	8AA	10AA / A	12AA		20AA
	67 (45)							D
	74 (50)	5A	6A	8A	10A	12A	16A	20A
	97 (65)				C			
	112 (75)		6B	8B		12B	16B	20B
	149 (100)		6C	8C		12C	16C	20C
	179 (120)				D			
	299 (200)				E			

◆ DESIGNATIONS NMX
 ◆ DESIGNATIONS NEMA
 ◆ DESIGNATIONS NEMA Y MX
 ◆ DESIGNATIONS CSA

In the cable management systems, the SWL is the maximum distributed load that the cable management system will support for a given deflection and distance between spans, respecting the established safety margins so as not to collapse. BASOR determines the SWL of its products through tests in its laboratory, according to the UNE-EN IEC 61537 and NEMA VE1 Standards.

In the supports and fastening elements, the SWL will depend on the type of installation, and therefore for each product different types of solutions will be defined, with their admissible workloads. For all those situations that are not defined as standards, BASOR's technical department will study each of the cases.

To determine the appropriate cable management system, the total LINEAR cost of the installation (conduit, supports, fixing systems, etc.) must always be considered, since the LINEAR cost of the supports and fixing elements, depends fundamentally on the distance between spans.

3.2 SAFE WORKING LOAD TESTS (SWL)

a) LOAD TESTS ACCORDING TO IEC 61537

To obtain the safe workload (SWL) of trays installed horizontally, the test methods are described in the IEC 61537 standard.

The SWL declared for the tray is obtained with a minimum margin of safety of 1.7 until collapses.

The maximum deflection in the middle of each span for the SWL should not be greater than 1/100 of the span.

The cross deflection of each span must not be greater than 1/20 of the width of the sample.

Three main types of tests are distinguished according to this standard, carried out with several spans.

The main ones are:

TYPE I Test When no indication is given on the limitations of the end spans, nor on the position of the joints in all installations. In this case the joints can be placed anywhere in the installation.

TYPE II Test When the manufacturer indicates that in no installation there should be joints in the end spans but does not limit their position in the rest of the installation.

TYPE III Test When the standard length of the tray is equal to the span length or a multiple of it, and the manufacturer indicates the position of the joint with respect to the support in all installations.



BASOR adopts the TYPE II test, which it considers suitable for the installation system for the following reasons:

- The Type II test allows the installer to have joints at any point between supports, except in the first and last spans.
- It is the usual assembly practice not to have joints in the first span. They can easily be avoided also in the last span by adding additional support or by reducing the length of the previous section of the tray.



Determination of SWL in multi-span (IEC 61537)



**b) LOAD TESTS ACCORDING TO NEMA VE1 / ANCE NMX-J-517
(Applicable regulations in USA and Canada)**

The configuration of this test is a single tray section, supported at its two ends. The test consists of increments of distributed load until collapse, establishing the admissible SWL with a safety margin of 1.5. Additionally, the admissible load test for rungs is also considered by applying a point load applied to the center of the same rung.

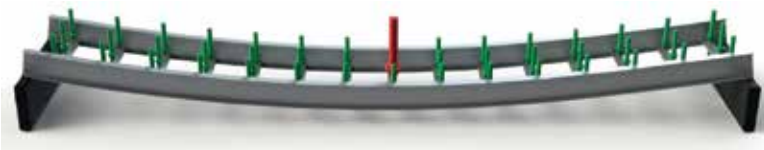

Determination of SWL in single beam (NEMA VE1)



After carrying out the tests with different models, and at different distances between supports, BASOR generates the necessary documentation.

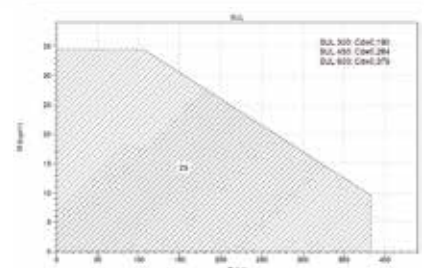
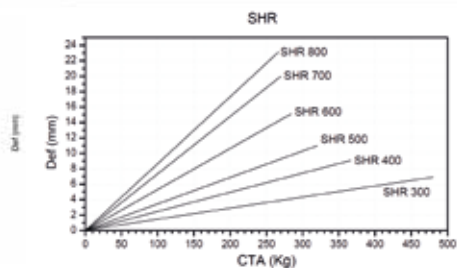
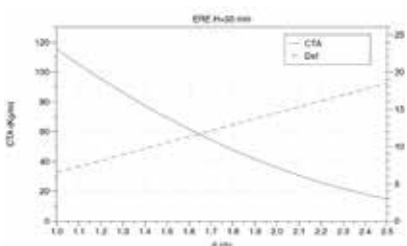

3.3 CABLE TRAY DIMENSIONS

DETERMINATION OF WORKING LOAD (WL)

Canalization systems must have an adequate mechanical resistance.

In order to select the most adequate canalization system, the workload (WL) must be known, and will depend on the load of the conductors it supports as well as on the additional design loads which are taken into consideration.

$$WL = Q_{\text{cable}} + Q_{\text{concentrated}} + Q_{\text{snow}} + Q_{\text{wind}} + \dots$$

Example:

Load of the conductors: 32 kg/m

Additional loads: 16 kg/m

Workload (WL): 48kg/m

In a system, there are different types of loads which can be considered. The designer shall be in charge of determining which loads are applicable in each case, depending on the conditions (location, environment, etc).



FOR THE CALCULATION OF LOADS AND THE DIMENSIONING OF THE CHANNEL, SEE THE APPENDIX.

SPAN LENGHT

A canalization's safe working load (SWL) is a characteristic which depends on the span length. As the span length increases, the safe working load decreases.

Choosing the right span length is a decision which shall depend on the system's conditions as well as on the cost of the cable conduction system (tray + support). In many cases, it is estimated that cable conduction systems with a lower SWL are cheaper but, in most cases, this is not true, as they require the installation of more supports and, therefore, the set-up time increases considerably.



IN MANY OCCASIONS, IT IS CONSIDERED THAT LOWER SWL CABLE MANAGEMENT SYSTEMS ARE MORE ECONOMIC AND THIS IN MANY CASES IS NOT TRUE, BECAUSE THEY REQUIRE TO INSTALL MORE SUPPORTS, AND THEREFORE, THE INSTALLATION TIME INCREASES CONSIDERABLY.

DEFLECTION

The deflection is the deformation generated in the canalization due to the workload .

According to Standard UNE-EN IEC 61535 with regards to the SWL, the longitudinal deflection located halfway through the span length must not be greater than $S/100$ of the span length and the transverse deflection must not be greater than $W/20$ of the canalization's width.

The NEMA VE1 standard does not currently cover the deflection.

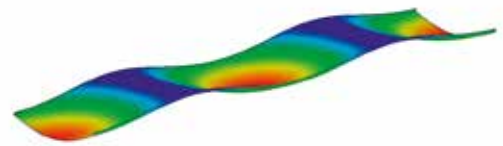

MINIMUM AREA OF THE CABLE TRAY (AMIN)

Another factor which shall affect the system's dimensions apart from the ones which have been explained up to now is the minimum area required by the system.

CABLE FILLING AREA

To determine the total cable-filling area, simply look at the useful section of each of the cables which shall run through the tray and add them up.

To calculate the empty spaces which shall inevitably be left between the cables, a cable's useful section shall be considered as the square of its diameter.

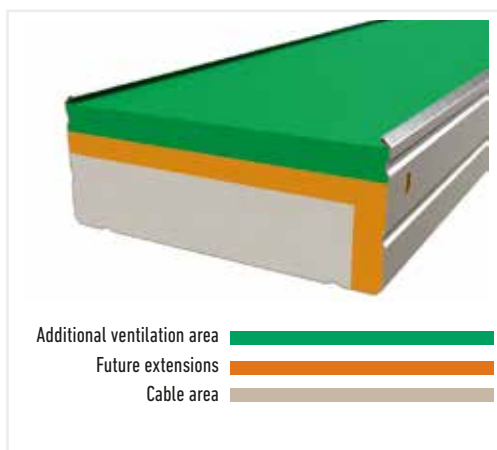

SECURITY COEFFICIENT (SC) FOR FUTURE ENLARGEMENTS

One of the many characteristics of cable trays is their capacity and ease of enlargement. Therefore, it is important to take into account a percentage of capacity to be used for future enlargements.

This way, the minimum area necessary for any common system shall be calculated as the summation of the useful sections of the cables and the subsequent application of the safety coefficient.

**BASOR
RECOMENDS
LEAVING AROUND 40%
FOR FUTURE
ENLARGEMENTS**

ADDITIONAL VENTILATION AREA

Depending on the system, the designer may decide to add another safety coefficient to the calculated area to ensure a good ventilation of the cables.

SPACE LIMITATIONS

One of the factors which may limit the choice is space limitations, regarding both the width and height available for the system's installation. BASOR recommends leaving a free space of between 150 and 300 mm between cable trays to facilitate access to the canalization system.

The distance shall depend on how easy it is to access the canalization and the need to handle it. Under no circumstance should the electrical system be placed under a system dealing with liquids.

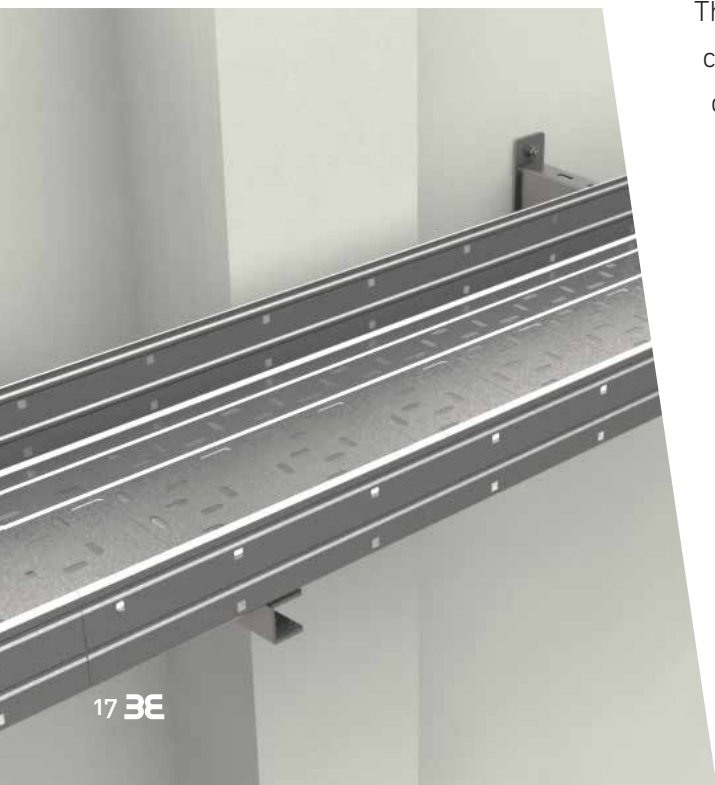

SECTION 4 ELECTRICAL CONTINUITY

Cable management systems are differentiated into two groups depending on their ability to conduct electrical current, in Systems with Electrical Continuity or Systems Without Electrical Continuity.

In Cable Tray systems with electrical continuity, we shall ensure equipotential connections throughout the whole system.



Cable systems without electrical continuity, we must ensure that the electrical resistance of the material's surface is high enough to avoid danger in case of a leakage.



4.1 TRAY SYSTEMS WITH ELECTRICAL CONTINUITY

The UNE-EN IEC 61537 standard "Cable management. Cable TCray systems and cable ladder systems" specifies the requirements that must be met in order to declare a tray system as a system "with electrical continuity".

These requirements are:

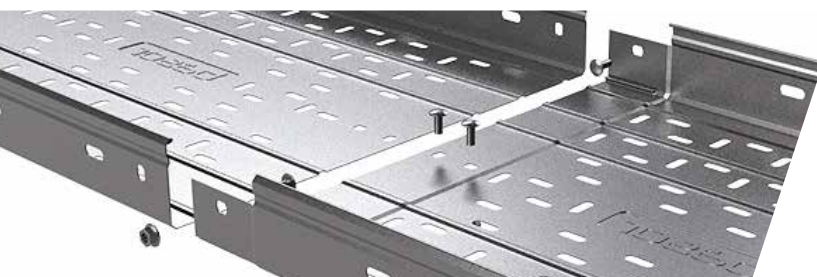

Impedance at the junction between pieces less than 50 mΩ

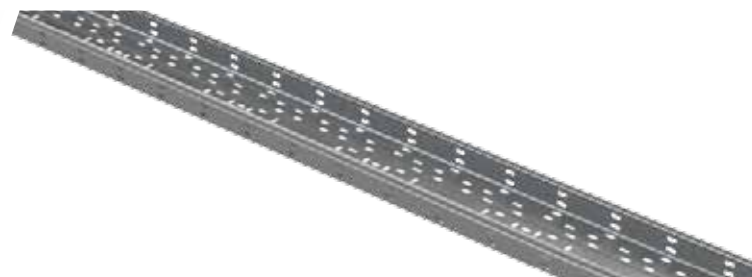

Impedance in the straight section less than 5 mΩ/m

The NEMA VE1 standard "Metal Cable Tray systems" also establishes the verification of electrical continuity and the tests to be passed, establishing a requirement of a Junction impedance lower than 0.33 mΩ

BASOR ELECTRIC metal cable trays comply with its product standard and have reached lower values in the relevant tests than those defined by the aforementioned standards.



Compliance with the standard ensures that the system has electrical continuity, and therefore, it is not necessary to use additional connections between the parts to ensure a correct bonding between them when installed according to the manufacturer's instructions and with suitable accessories.

4.2 ELECTRICALLY NON-CONDUCTIVE SYSTEMS

The UNE-EN IEC 61537 standard specifies the requirements that must be met to declare a tray system as an electrically non-conductive system.

These requirements are:

- Surface resistivity 100 M. Tested by surface resistivity test, with the application of a voltage of 500V DC for 1 minute and measurement of the resistance.

The main advantages of non-conductive trays and trunkings are:

Protection against indirect contact: the insulation tray systems are safe against indirect contact without the need to make connections to the earth network.

Avoid leakage of currents: by avoiding leakage of currents, you avoid possible hot spots and electrical arcs.



According to the American standard UL 568 "Nonmetallic Cable Tray Systems", the tray shall have enough dielectric strength to withstand the ASTM D 149 test with the application of a voltage of 5000V DC for one minute without perforation, except for trays expressly designed for dissipate static electricity.

SECTION 5 ELECTROMAGNETIC COMPATIBILITY

Electromagnetic compatibility is covered by the EMC Directive 2014/30 / CE.

It is the ability of an installation, a device or a system to work satisfactorily in its electromagnetic environment, and without itself producing electromagnetic disturbances that can cause serious problems in the operation of other devices or systems in your environment.



IS OF PARTICULAR IMPORTANCE WHEN COMMUNICATIONS CABLING IS PRESENT, WHICH MAY BE AFFECTED BY DISTURBANCES FROM ITS SURROUNDINGS OR FROM OTHER NEARBY POWER CABLING.

RELATIONSHIP WITH THE EARTH NETWORK AND THE BONDING SUMP PROBLEMS

- The ground network is connected to an electrical ground, where its function is to guarantee the protection of people.
- The equipotential bonding of all the parts has a role in the fight against electromagnetic disturbances and a functional role in the transmission of information.

In order to achieve an ideal earthing and grounding system, the separation of these two networks is recommended. In practice, as these two networks are closely connected, it is necessary to achieve almost full equipotential bonding by securing the connections all the way around. This compensates for the problem of high impedance of the earth conductors, due to the long length and the star topology.

5.1 BEHAVIOUR OF CABLE MANAGEMENT SYSTEMS

According to the UNE-EN IEC 61537 standard, cable management systems (CMS) are passive elements, in normal use, with respect to electromagnetic influences, emission and immunity.

Non-metallic CMS, such as PVC, are transparent to electromagnetic effects, so they cannot attenuate them, but neither do they amplify possible electromagnetic disturbances internal.



If a metallic CMS has good electrical continuity and is well-grounded it decreases the coupling of the disturbance on the cables, by eliminating the induced current, improving Electromagnetic Compatibility (CEM).



If the CMS is electrically continuous, it is and also formed by a tray and its cover, protection against disturbances improves substantially.

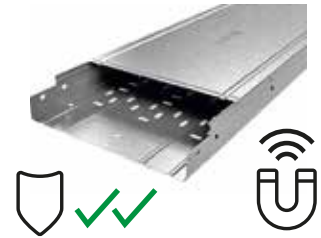

CMS, which are not electrically continuous, do not protect against electromagnetic fields. In this case the only solution to improve electromagnetic compatibility is to increase the distance among CMS.

5.2 RECOMMENDATIONS FOR AN INSTALATION GOOD EMC

In practically all buildings there are wiring of communications. To guarantee its reliability the quality of the cabling and also of the CMS is essential. European regulations on electrical installations HD 60354-4-444 regulates the protection against electromagnetic disturbances.

The current regulation on telecommunications cabling EN 50174-2 indicates that the cable management system can help to reduce electromagnetic interference:

- Through a shielding in the contained circuits in the cable management system.
- Improving the coexistence between circuits contained in the cable management system, through effective separation of data and power cabling.
- Reducing the disturbances between the different circuits contained in the cable management system, produced by the currents in the cables that circulate through them..

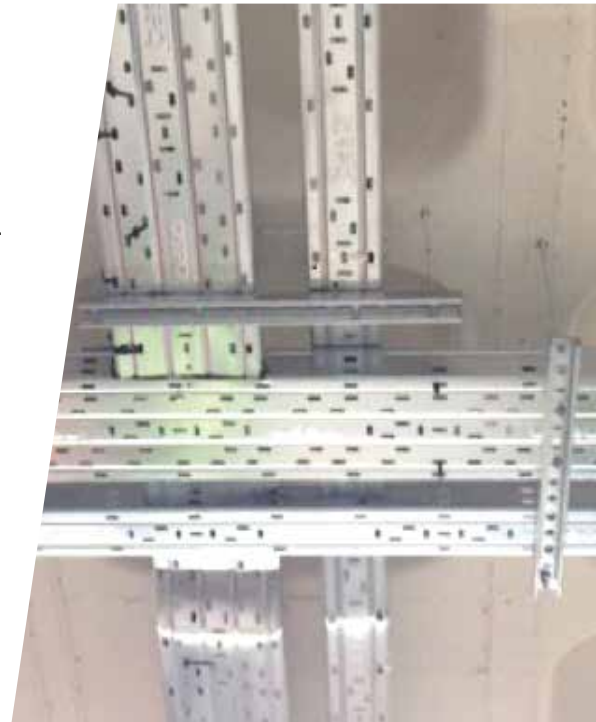

ELECTROMAGNETIC SHIELDING EFFECTS OF THE CMS

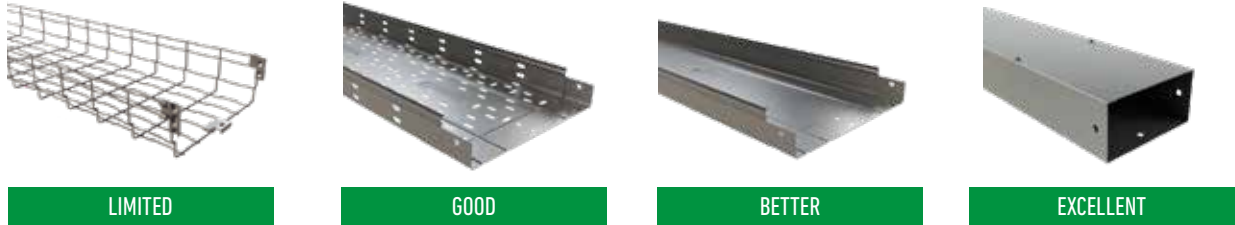

- Different types of trays have different behavior, depending on the degree of shielding they provide.
- Inside corners provide the best protection.
- For a given internal cross-sectional area, having tall sidewalls provide greater useful capacity.

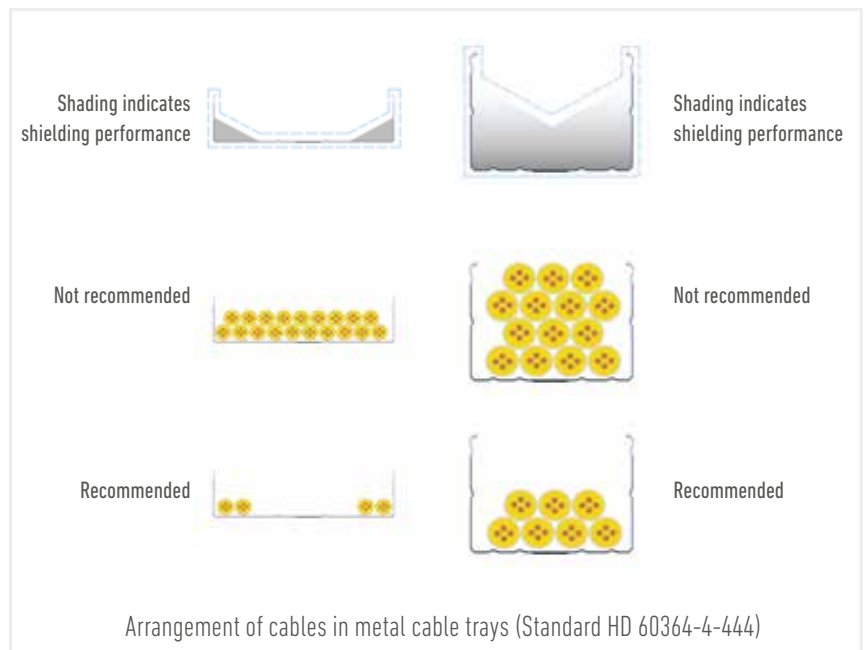

INSTALLATION CONSIDERATIONS

BASOR RECOMMENDS:
SEPARATING POWER AND DATA CIRCUITS MORE THAN 20 CM



CIRCUITS MUST CROSS ONE ANOTHER AT AN ANGLE OF 90°



CONNECT THE CABLE MANAGEMENT SYSTEMS TO THE EQUIPOTENTIAL GROUND NETWORK EVERY 100 M

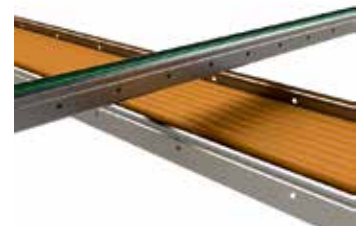
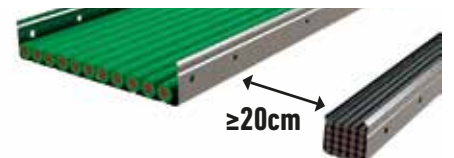

In situations where space is limited, different circuits can be installed in the same CMS dividing by means of a metallic separator. With correct installation that guarantees electrical continuity, it is NOT necessary to include a copper wire throughout the entire tray.

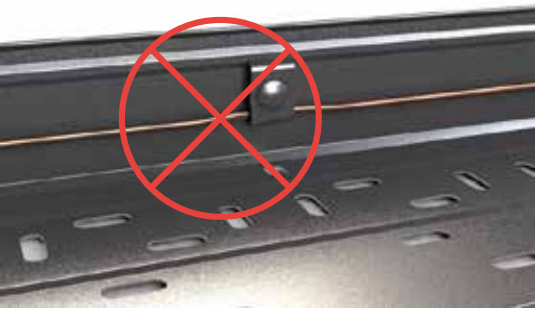
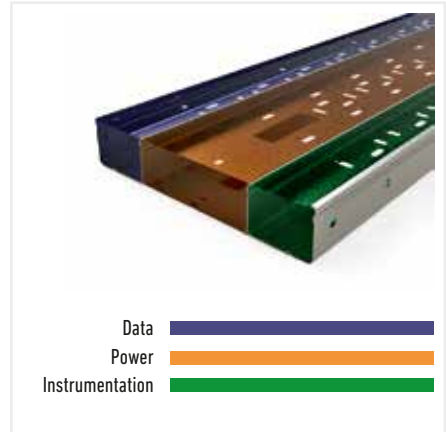

ASSEMBLY OF THE CABLE RUNWAY AND CONSTRUCTION OF ACCESSORIES

It is important, in order to guarantee correct EMC protection, that the equipotential bonding is maintained along the entire cable runway, so as to facilitate the elimination of high-frequency currents.

Examples of maintaining the continuity of the metallic components of the system to provide protection to electromagnetic compatibility.

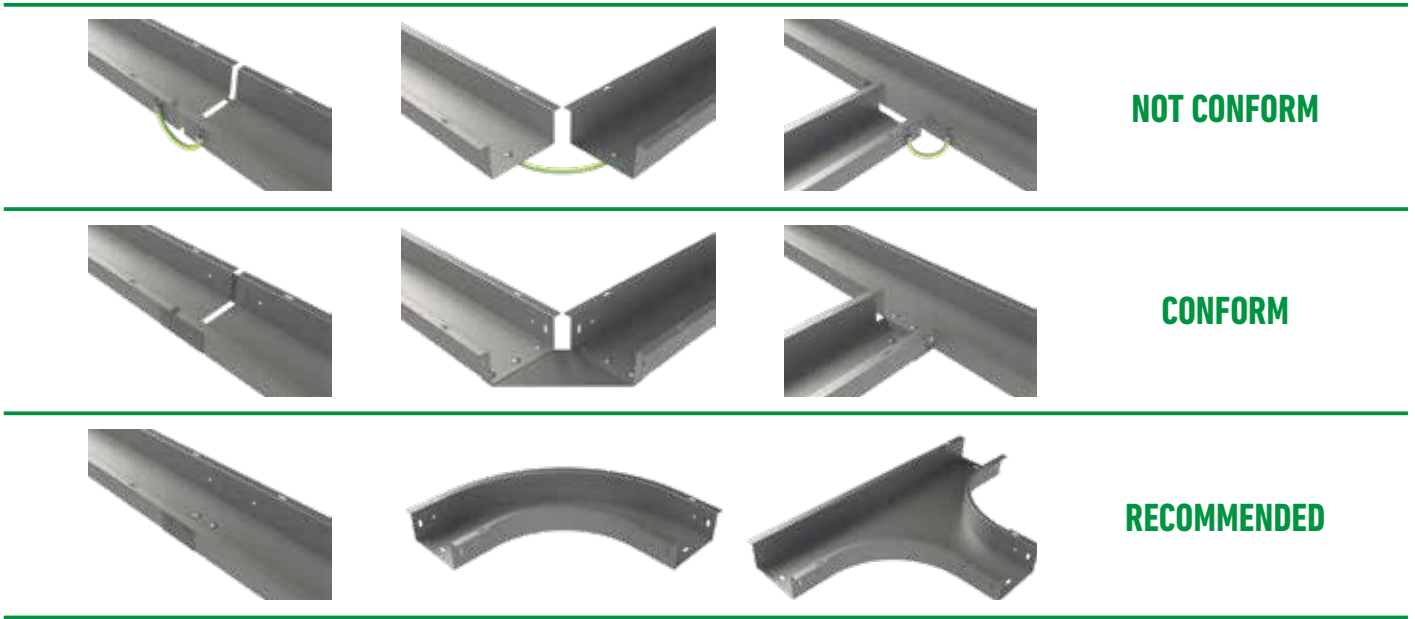

(Figure 44.RZ4 Standard HD 60364-4-444)

SECTION 6

SERVICE TEMPERATURE: THERMAL CONTRACTIONS AND EXPANSIONS

Service temperatures are the temperature range of the cable management system in its installation and use, without the system suffering a decrease in its technical characteristics.

In all cable management systems, we must indicate the maximum temperature and minimum of service. If the temperature range is wide, we must consider the effect of contraction and expansion of materials.

This effect stretches or contracts the material depending on the coefficient of expansion of the material. In order to measure the effect of expansion and compression, one must compare the material at two different temperatures, and therefore it is important that in the design of cable duct systems, the range of service temperatures in which it will be used is considered. At first glance, the contraction / expansion effect is not perceptible, although in large lengths of trays lines the effect is accentuated.



Our joining systems use longitudinal holes to absorb the movements due to thermal expansion. BASOR advises separating the straight sections leaving space for the joints to act as expansion joints and allow these movements. The length of the section of trays, the difference in service temperature and the material will determine the maximum length of straight section to install the joint as an expansion joint.

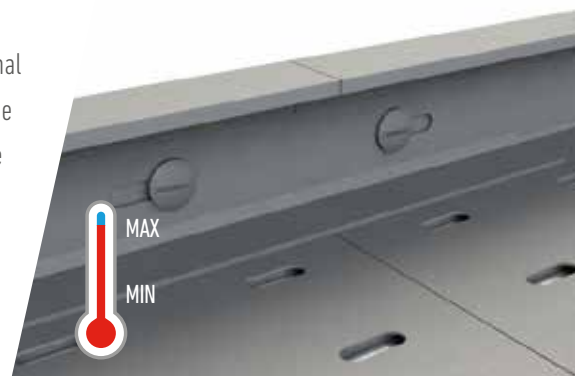

In installations of PVC trays with high temperature changes, could be necessary to install tray sections separated between 5 and 10mm from each other, depending on the increase in expected temperature, due to the high coefficient of linear expansion of the material. Check product data sheet.

DISTANCE (METRES) BETWEEN EXPANSION JOINTS*				
TEMPERATURE DIFFERENCE (°C)	STEEL (m)	STAINLESS STEEL (m)	ALUMINIUM (m)	PVC (m)
20	38	31	22	7,1
30	25	21	14	4,8
40	19	15	11	3,6

* For a maximum dilation of 10mm.

SECTION 7 VENTILATION AND DEGREE OF AIRTIGHTNESS

Choosing the trays with greater ventilation will substantially improve the working temperature of the conductors for the same intensity. On the other hand, blind trays (not perforated) offer a higher level of protection against external agents.

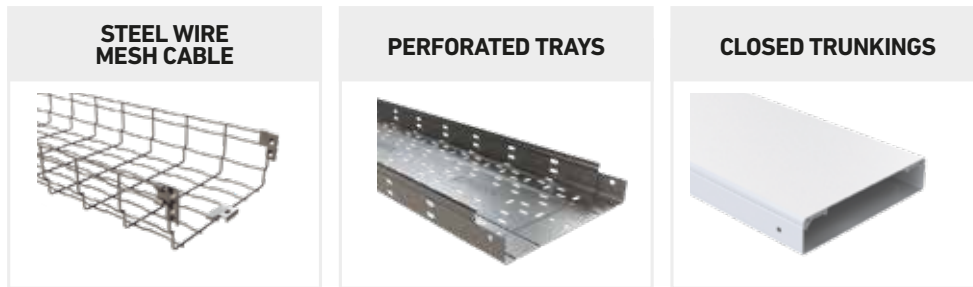

Depending on the type of installation, an attempt will be made to achieve lower working temperatures in the conductors to improve the performance of the installation, or simply seek greater protection against the penetration of any external agent into the cable runways.

The IP Code is used to indicate the degree of tightness of the piece to water or dust, as well as the protection against the entry of objects, and therefore against the possible contact of people with the interior parts.

Description of the IPXX Code according to the UNE-EN 60529 standard

The first characteristic figure indicates the protection AGAINST THE ENTRY OF FOREIGN OBJECTS solid:

- 0) Not protected
- 1) $\geq 50\text{mm}$ diameter
- 2) $\geq 12.5\text{mm}$ diameter
- 3) $\geq 2.5\text{mm}$ diameter
- 4) $\geq 1\text{mm}$ diameter
- 5) Protected against dust
- 6) Fully protected against dust

The second characteristic figure indicates the Protection AGAINST PENETRATION OF WATER with detrimental effects:

- 0) Not protected
- 1) Protected against vertical drops of water drops
- 2) Protected against falling water with max. inclination 15th
- 3) Protected against water in the form of rain
- 4) Protected against water splashes
- 5) Protected against water jets
- 6) Protected against strong jets of water
- 7) Temporary immersion
- 8) Continuous immersion

SECTION 8 MATERIALS: CORROSION, DEGRADATION AND LIFETIME

As we have introduced in Section 1 "Selection of Cable Management Systems", depending on the mechanical, electrical, corrosion resistance, etc. properties, one material or another should be used together with a finish suitable for the environmental conditions to which the installation is subjected.

Corrosion is defined as the deterioration of a material by its environment, as a result of an electrochemical reaction (oxidation). It is a natural and spontaneous process.

The speed at which it takes place will depend on several factors: temperature, humidity, the presence of corrosive substances, the salinity of the fluid in contact with the metal and the properties of the metals in question.

Other non-metallic materials, such as thermoplastics, also suffer degradation, but by different processes.



8.1 CORROSION AND LIFETIME



In general, USEFUL LIFE TIME is understood as the duration estimated that an object can have, fulfilling correctly with the function for which it has been manufactured.

In the case of cable trays, it will therefore be the time during which the tray will be able to adequately support the cables. Corrosion is a determining factor in the useful life of the trays because it can compromise their mechanical resistance.

A choice of the corrosion resistance system that does not consider the useful life of the product can have very important repercussions, such as high permanent maintenance costs.

The SERVICE LIFE of metal parts will be affected by corrosion phenomena, depending on the environmental conditions or other phenomena.

The main types of corrosion that we can distinguish are:



STEEL PROTECTION SYSTEMS AGAINST CORROSION

There are basically two ways to prevent steel corrosion:

PROTECT THE BASE

HOT GALVANIZED
(BEFORE OR AFTER THE MANUFACTURE OF THE PART)

ELECTROLYTE COATINGS

PAINTINGS

CHANGE THE STEEL'S OWN
CHEMICAL STRUCTURE

STAINLESS STEELS

8.2 ATMOSPHERIC CORROSION

Atmospheric corrosion is corrosion caused when metal is exposed to liquids, solids or gases carried in the atmosphere. Moisture, salt, corrosive gases and dirt are the main factors. This type of corrosion occurs in the open air, in places with poor ventilation and in marine environments.

The electrolyte is normally made up of an extremely thin film of moisture that is not visible to the naked eye, or of an aqueous film, when the metal is wet due to rain or dew. Relative humidity has been shown to play a decisive role in atmospheric corrosion.



In some classifications, salt corrosion is studied independently, since the metallic surface is exposed to different saline concentrations, sometimes forming a galvanic cell where the surface exposed to the lowest salt concentration behaves as the anode.

For metallic elements with protection by zinc coatings (Galvanized, Electroplated, etc.), the UNE-EN ISO 14713-1 Standard allows estimating the USEFUL LIFE of the coating according to its micron size and the corrosivity of the environment, for which they are defined corrosion rates in microns / year for different categories of environments:

DURABILITY OF ZINC COATINGS			EZ	GS-PG	EZ1000	HDG (45µm)	HDG (70µm)	HDG (85µm)	PGP	HDGP ** DUPLEX	
CORROSIVITY CATEGORY (ACCORDING TO ISO 14713-3)	C1 VERY LOW	DRY INTERIOR, NORMAL ENVIRONMENT OUTSIDE DRY OR COLD AREA WITHOUT POLLUTION	TYPE OF ENVIRONMENT	OFFICES, SCHOOLS, MUSEUMS, DESERTS OR ARCTIC AREAS	◆	◆	◆	◆	◆	◆	◆
	C2 LOW	INTERIOR WITHOUT TEMPERATURE VARIATION OR TEMPERED OUTSIDE WITH LOW POLLUTION		WAREHOUSES, SPORTS CENTERS DRY RURAL AREAS, SMALL CITIES	◆	◆	◆	◆	◆	◆	◆
	C3 MEDIUM	MODERATE CONDENSATION AND POLLUTION TEMPERATE OUTSIDE, MEDIUM POLLUTION		PROCESSING PLANTS, DAIRY, LAUNDRY URBAN OR COASTAL AREA WITH LITTLE SALINITY	◆	◆	◆	◆	◆	◆	◆
	C4 HIGH	HIGH CONDENSATION AND POLLUTION TEMPERATE OUTSIDE, HIGH CONTAMINATION		INDUSTRIAL PROCESS WITH HUMIDITY, POOLS INDUSTRIAL POLLUTED AREA, COASTAL	◆	◆	◆	◆	◆	◆	◆
	C5 VERY HIGH	FREQUENT CONDENSATION AND POLLUTION HIGH PRESENCE OF CHLORIDES OR CONTAMINATION		UNDERGROUND, MINES, VENTILATED VESSELS INDUSTRIAL COASTAL ZONE, UNDER ROOF IN COASTAL	◆	◆	◆	◆	◆	◆	◆
	CX EXTREME	PERMANENT CONDENSATION AND POLLUTED HUMID OR HEAVILY POLLUTED TROPICAL ZONE		UNVENTILATED WAREHOUSES IN SALT TROPICAL ZONE SEVERE INDUSTRIAL ZONE, MARINE ENVIRONMENT	◆	◆	◆	◆	◆	◆	◆

DURABILITY IN YEARS ACCORDING TO ACCUMULATED LOSS OF THICKNESS (ANNEX A UNE. EN ISO 9244)
 ** CONSIDERED INCREASED DURABILITY DUE TO THE PROTECTION OF THE ORGANIC COATINGS / ISO 12944-5

◆ VERY LOW ◆ LOW ◆ MEDIUM ◆ HIGH ◆ VERY HIGH

VERY LOW: 0 to <2 years HIGH: 10 to <20 years
 LOW: 2 to <5 years VERY HIGH: > 20 years
 MEDIUM: 5 to <10 years

The main zinc coatings are:

- GS-PG** Galvanized Steel in continuous before manufacturing and by Sendzimir procedure
- EZ** Electroplated steel
- GC-HDG** Hot Dip Galvanized Steel after manufacturing

- EZ1000** Improved Electroplated Steel, with high layer passivation and sealing, with resistance in Salt Mist > 1000h
- GSP** Sendzimir steel coated with polyester resin, with resistance in Salt Fog > 1000h
- GCP** Hot-dip galvanized steel after manufacture, coated with polyester resin



Stainless steels have greater resistance to corrosion, since when reacting with the oxygen forms a passively continuous, very resistant and stable chromium oxide film on the surface of them. The correct formation of this passive layer will depend on the finishing treatments received after manufacture.

However, it can be attacked in aggressive environments by some types of corrosion localized that can lead to pitting or cracking. With the addition of different elements in the alloy, it is possible to improve the resistance to corrosion, in addition to other mechanical characteristics, for which they are defined in the standards Different European Corrosion Resistance Classes (CRC), according to the chemical composition of the stainless steel.

The following Table shows the main types of Stainless Steel according to their greater resistance to corrosion, according to UNE-EN 1993-1-4 "Eurocode 3. Steel structures. Part 1-4: Steels stainless".

PRINCIPALES TIPOS DE ACERO INOXIDABLE UTILIZADOS			
CORROSION RESISTANCE CLASS CRC	DESIGNATION IN SYMBOLIC	DESIGNATION IN NUMERIC	OTHER DESIGNATION (AISI)
I	X2CrNi12	1.4003	430
II	X2CrNi18-9	1.4307	304L
III	X2CrNiMo17-12-2	1.4404	316L
IV	X2CrNiMoN22-5-3	1.4462	2205
V	X1NiCrMoCuN25-20-7	1.4529	926

i304
i316

8.3 CHEMICAL CORROSION

Chemical corrosion occurs when metal is exposed directly to chemical solutions. Depending on the level of solution concentration, contact time, frequency cleaning and operating temperature, the level of the corrosion will be more or less.

Plastic materials, such as PVC, have good behavior against many chemical products, as indicated by the DIN 6081 and ISO TR 10358 standards.



Similarly, stainless steels provide greater resistance to chemical corrosion than Zinc coatings. Especially suitable for saline environments is i316 stainless steel.

IN THE APPENDIX OF THIS TECHNICAL GUIDE, YOU CAN CONSULT THE CHEMICAL COMPATIBILITY TABLES.

8.4 STORAGE CORROSION

In some cases (zinc coated steels) when the material is stored in places poorly ventilated and damp, white spots appear on surfaces. Generally, white spots are superficial and do not affect the properties of the coating, although cleaning is recommended so that the protective layer can form correctly.



The material should be stored in a ventilated and dry place, always avoiding storage outside, even with low humidity.

8.5 GALVANIC CORROSION

It is a common phenomenon, and it is established when two different metals are in contact with each other. When two different metals come into contact, a small galvanic couple is created when a metal acts as an electrical anode and the other as an electrical cathode, creating a current of electrons between them.

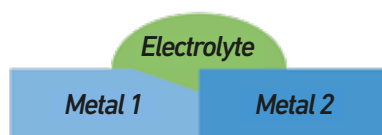

Anode 
Cathode 

The one with the most negative reduction potential will be oxidized and the one with the most positive reduction potential will be reduced.

It is important to bear in mind that for galvanic corrosion to occur, three conditions must be present simultaneously:

- Union of two metals with Galvanic Potential Difference
- Physical contact between metals
- Moisture conductive film on the surface (electrolyte)

GALVANIC CORROSION CANNOT OCCUR

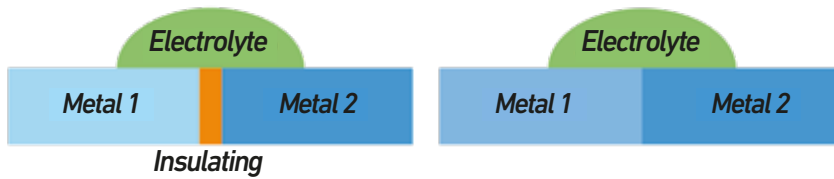

... NO ELECTRICALLY CONDUCTIVE JOINTS

... IN METALS WITHOUT DIFFERENCE OF POTENTIAL

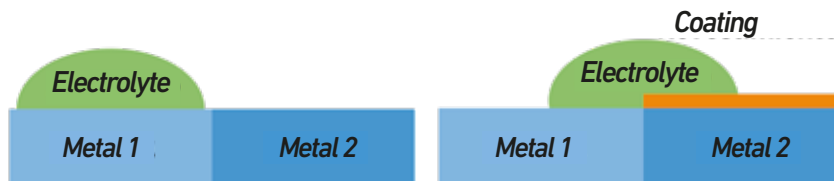

...NO CONNECTION THROUGH AN ELECTROLYTE



Anode 
 Cathode 

The main factors that determine the appearance of galvanic corrosion are:

The contact area between the pieces

Will be proportional to the attack suffered by corrosion.

When the attacked piece has larger surface than the part, the corrosion, that produces the galvanic effect will be very slow.



● STAINLESS STEEL
● GALVANIZED STEEL

In the same way, a small area of the weak part will accelerate corrosion against large piece.



● STAINLESS STEEL
● GALVANIZED STEEL

The environment in which it is located

Higher temperature and humidity will favor the oxidation.

The corrosion rate will depend on the continued presence or not of moisture that forms the electrolyte layer, and conductivity, which will vary according to the presence of salinity and pollutants.

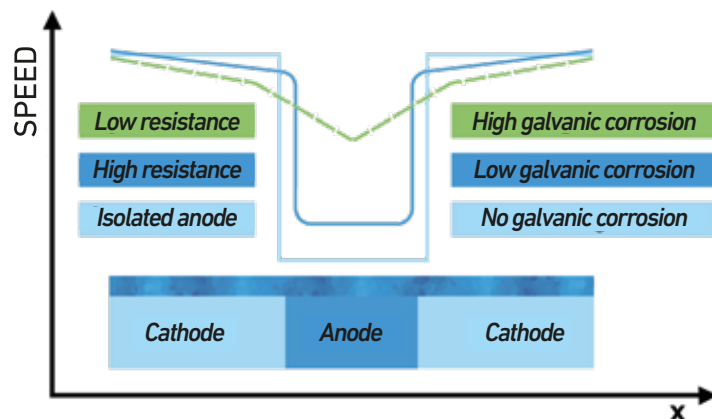

The materials affected

Depending on the level of galvanic potential between them, the intensity of corrosion could be higher, reducing the useful life of the anodic material.

TABLE: GALVANIC POTENTIAL DIFFERENCE (mV) BETWEEN DIFFERENT METALS

In the following Table of galvanic potentials, the compatibility of the union between different metals is indicated. Values below the red line indicate that there is a considerable risk of galvanic corrosion.

- ◆ COMBINATIONS OF METALS WITH HIGH GALVANIC POTENTIAL
- ◆ COMBINATIONS OF METALS WITH MEDIUM GALVANIC POTENTIAL
- ◆ COMBINATIONS OF METALS WITH LOW GALVANIC POTENTIAL

	ACERO INOX.	NIQUEL (Ni)	COBRE (Cu)	LATÓN (Cu-Zn)	BRONCE (Cu-Sn)	ACERO FUNDICIÓN	ACERO AL CARBONO	ALUMINIO	HIERRO DULCE	CROMO	ZINC (Zn)
STAINLESS STEEL	0										
NICKEL (Ni)	180	0									
COPPER (Cu)	320	140	0								
BRASS (Cu-Zn)	400	220	80	0							
BRONZE (Cu-Sn)	520	340	200	120	0						
CAST STEEL	700	520	380	300	180	0					
CARBON STEEL	750	570	480	350	230	50	0				
ALUMINIUM	840	660	520	440	320	115	90	0			
SOFT IRON	855	675	535	455	335	155	105	15	0		
CHROME	950	770	630	550	430	250	200	110	95	0	
ZINC (Zn)	1150	970	830	750	630	450	400	310	295	200	0

SELECTION OF ACCESSORIES IN CABLE MANAGEMENT SYSTEMS

In the installation of cable trays or ladders, due to the smaller relative surface the accessories may suffer galvanic corrosion, which will be faster in humid environments or aggressive and depending on the materials:

ACCESSORIES -SUPPORTS -SCREWS	CABLE TRAY / LADDER MATERIAL				
	ZINC COATING		ALUMINIUM	STAINLESS	
	EZ	GC	AL	i304	i316
	EZ	GC	AL	i304	i316
	GREEN	RED	RED	RED	RED
	GREEN	GREEN	GREEN	GREEN	GREEN
	i304	i316			
	GREEN	GREEN	GREEN	GREEN	GREEN

- EZ Electrogalvanized steel
- GC Hot Dip Galvanized Steel after fabrication
- i304 AISI 304 Stainless Steel
- i316 AISI 316 Stainless Steel
- AL Aluminum (Alloys 1050, 5754, 6063, etc.)

8.6 CLASSIFICATION AGAINST CORROSION IN THE PRODUCT STANDARD

The EN IEC 61537 Standard classifies the most common materials and coatings according to the degree of resistance to corrosion in 'classes' from less resistant to more resistant. With this type of classification, you can define the minimum class required for each type of installation.

In addition, and for materials NOT LISTED in the table, allows establishing an equivalence between the class of corrosion resistance and the duration of the neutral salt spray test (NSS Test) according to the ISO 9227 standard, allowing manufacturers and engineers to classify new finishes or materials.

CLASS	REFERENCE- MATERIAL AND COATING	DURATION (h) NSS TEST*
0*	None	-
1	Electrolyte deposit up to a minimum thickness of 5 µm	24
2	Electrolyte deposit up to a minimum thickness of 12 µm	96
3	Pre-galvanized grade 275 in accordance with Standard En 10327 and Standard EN 10326	155
4	Pre-galvanized grade 350 in accordance with Standard En 10327 and Standard EN 10326	195
5	Hot dip galvanized with a zinc coating thickness of 45 µm (minimum) according to ISO 1461 only for zinc thickness	450
6	Hot dip galvanized with a zinc coating thickness of 55 µm (minimum) according to ISO 1461 only for zinc thickness	550
7	Hot dip galvanized with a zinc coating thickness of 70 µm (minimum) according to ISO 1461 only for zinc thickness	700
8	Hot dip galvanized with a zinc coating thickness of 85 µm (minimum) according to ISO 1461 only for zinc thickness (Typically high silicon steel)	850
9A	Stainless steel manufactured to ASTM Standard: A 240 / A 240M - 95a designation S30400 or EN 10088 grade 1-4301 without post-treatment **	-
9B	Stainless steel manufactured to ASTM Standard: A 240 / A 240M - 95a designation S31603 or EN 10088 grade 1-4404 without post-treatment **	-
9C	Stainless steel manufactured to ASTM Standard: A 240 / A 240M - 95a designation S30400 or EN 10088 grade 1-4301 with post-treatment **	-
9D	Stainless steel manufactured to ASTM Standard: A 240 / A 240M - 95a designation S31603 or EN 10088 grade 1-4404 with post-treatment **	-

* For materials that do not have a declared corrosion resistance rating.

** The post-treatment process is used to improve protection against crevice corrosion and the contamination produced by other steels.

SECTION 8 — MATERIALS: CORROSION, DEGRADATION AND LIFETIME

For zinc coatings, it is possible to estimate the useful life of the material from the values corrosion rate, which come from the EN ISO 14731 Standard and the different types of environment, for each type of finish, as reflected in the Table “Durability of coatings of Zinc” from the beginning of the section.

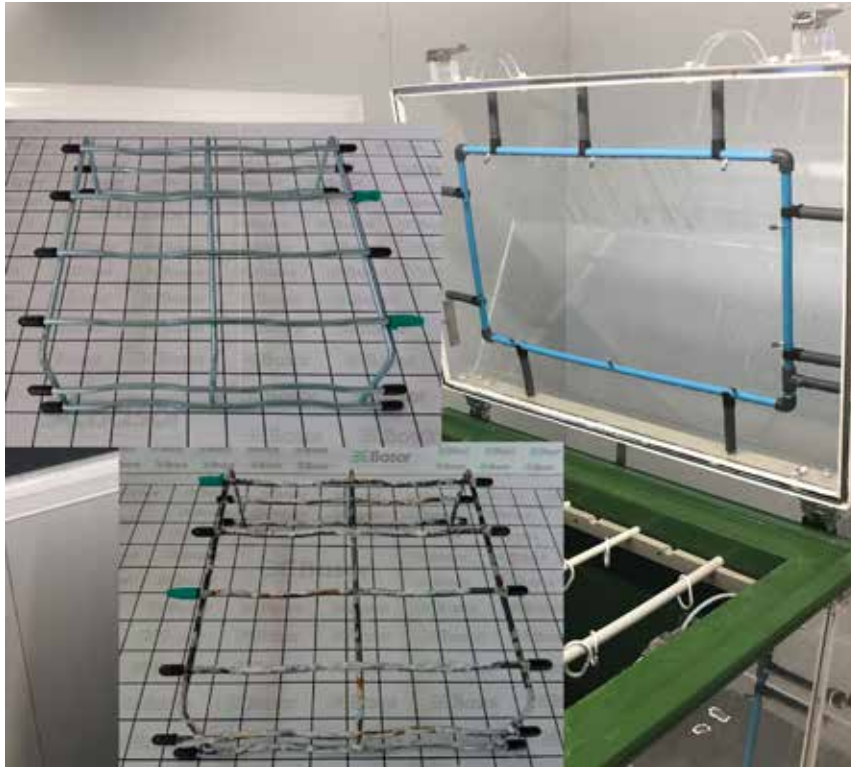

Accelerated corrosion test in a salt spray chamber.



BEBasor
CABLE TRAY SPECIALIST

BASOR ELECTRIC S.A. HEADQUARTERS

Avenida Alcodar 45-47
46701 Gandia SPAIN
+34.96.287.6695